

RMF SYSTEMS

PURE POWER



AIR CONDITIONER DESICCANT BREATHER



Benefits RMF 'Air conditioner'

- ▶ Reducing water contamination level prolongs the life of the additive package and reduces oxidation of the oil and bearing surfaces.
- ▶ Eliminates rusting due to condensation.
- ▶ Reduces machine downtime.
- ▶ Extends the machine's useful life.
- ▶ Reduces cost of ownership.

Air conditioners

CONDENSATION IN RESERVOIRS

HYDRAULIC AND LUBRICATING OILS MUST BE KEPT FREE FROM CONTAMINATION AND WATER. MOST FLUID RESERVOIRS MUST BE ABLE TO BREATHE, THUS ALLOWING WATER VAPOUR AND SOLID CONTAMINANTS TO ENTER. TEMPERATURE FLUCTUATIONS IN THE RESERVOIR WILL CAUSE THIS WATER VAPOUR TO CONDENSE WHICH WILL NOT ONLY CAUSE OXIDATION OF THE OIL, BUT CAN ALSO LEAD TO CONSIDERABLE MECHANICAL DAMAGE.

FILTRATION AND DRYING A SINGLE PROCESS

Standard air breathers remove some of the solid particles but allow water vapour in the air to pass freely. The RMF 'Air conditioner' deals effectively with both so reservoirs can breath clean, dry air. The air is first dried by passage through a column packed with ZR gel granules. The dried air is then passed through a pleated synthetic fibre filter element (replaceable spin-on type) where solid particles are removed,

so that the air reaching the reservoir is both clean and dry.

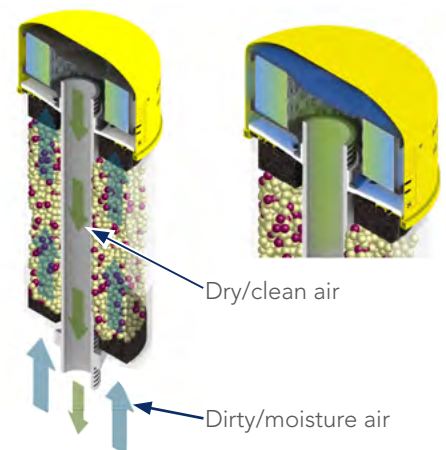



MONITORING

The uptake of moisture can be observed by the change in colour of the indicator granules in the ZR gel. They turn from ruby-red (active) to light orange (replace). The ZR gel granules are completely replaceable, non toxic and non carcinogenic. An optional contamination indicator shows when the air filter is in need of replacement.

ACTIVE COAL

RMF 'Air conditioners' can be fitted with a combination of ZR gel and active coal, the active coal will eliminate oil vapour and the smell, it will also prevent the ZR gel from being contaminated with this oil damp.



ATMOSPHERICALLY CLOSED

The RMF range also offers some 'Air conditioners' for gearbox applications which have spring loaded (0.01 bar) check valves fitted in the base in opposing directions, opening only whilst inhaling or exhaling. This way there is no atmospheric contact with the air and the ZR gel under static conditions increasing the lifetime of the drying agent.

APPLICATIONS

RMF 'Air conditioners' can be used on hydraulic power units, lube and oil tanks, gearboxes, diesel fuel tanks and storage tanks for biodegradable fluids. Industries that are successfully applying 'Air conditioners' include: steel industry, aviation industry, forestry industry, pulp & paper industry, cement industry, petrochemical industry and mining industry.

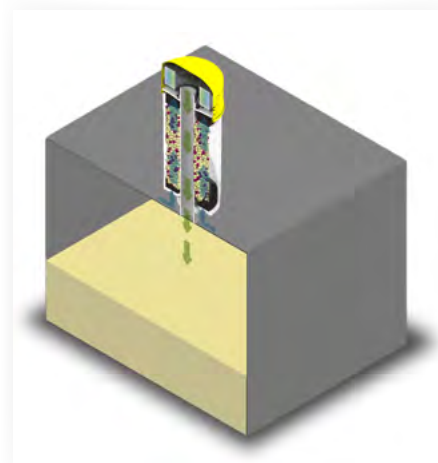

Air Conditioners Accessoires

BENEFITS RMF OIL-DEMISTERS

- ▶ Reduces premature filter exchange
- ▶ Reduces fluid spills on machine surfaces
- ▶ Reduces environmental risks
- ▶ Reduces fluid waste
- ▶ Reduces safety issues with oil spills
- ▶ Reduces cost of ownership

WHERE CAN IT BE USED

RMF Oil-Demisters can be used on:

- ▶ Hydraulic power units
- ▶ Lube and oil tanks
- ▶ Gearboxes
- ▶ Pump vents
- ▶ Pulp Refiners

OIL-DEMISTERS

THE RMF SYSTEMS OIL-DEMISTERS ARE SPECIALLY DESIGNED TO PREVENT OIL MIST OR FLUID MIGRATION THROUGH AIR VENTS. THE RMF DEMISTER CONSISTS OF AN ALUMINIUM BODY WITH EXTERNAL COOLING RIBS AND CAN BE FITTED BELOW THE AIR CONDITIONER OR AIR FILTER.

Inside this aluminium body a coalescing post is positioned. When migrating oil vapor rises up this post the vapor coalesces into oil droplets which run down the outer diameter of the post and are guided back to tank through holes at the base of the post. In case of excessive splash the oil is contained in the post and runs down the slits in the post and is also returned to the reservoir.

OIL MIST

Air vents are used to compensate changes in air volume above the fluid level in gear boxes, hydraulic reservoirs, pump housings etc. High temperatures and thermal expansion cause migration of oil vapors through the air vent, blocking air filters and causing oil spills on machine surfaces. These fluid spills cause both an environmental and safety issue, they are also the cause of shortened air filter life and avoidable fluid consumption. In case of dynamic, volatile gearbox systems not only Oil Mist can migrate through air vents, but fluid splash can cause extreme fluid migration.





MOUNTING PLATES

RMF offers a range of Mounting or Adaptor Plates that can be fitted to hydraulic reservoirs, the mounting plates all have the standard DIN-24557/2 pattern. Mounting plates range from simple fitting of air conditioner only, mounting plate with additional port for vacuum indicator (Filter Minder), to mounting plates with additional porting, connection for suction and



return off Off-line filters.

The mounting plates allow for simple and quick air conditioner and off line filter installation without the need for welding/ drilling etc. The sealing on the tank lid is achieved by an 'O' ring which is part of delivery. The mounting plates can be used with all RMF Systems Air Conditioners.

FILTER MINDER

To monitor the state of the air filter, RMF Systems offers a Filter Minder (vacuum switch).

The filter minder is a combination graduated indicator and switch (N/O), a yellow indicator moves up in the window and locks at the highest air filter restriction. When it reaches the red zone, or highest recommended restriction, it closes a contact and can send a signal to the filter warning light. The locked position at highest restriction must be reset manually. The filter minder can be fitted to a variety of the RMF Mounting or Adaptor Plates.



Air conditioners Specifications

LIGHT VERSION SERIES ACL..R / ACM..R			
TYPE	ACL93R (C)	ACL96R (C), (V)*	ACM61R
Total weight	0.9 kg	1.1 kg	0.4 kg
ZR gel volume	300 cc	600 cc	100 cc
Water absorption	86 gram	172 gram	29 gram
Max. air flow	700 l/min	700 l/min (300 l/min)	50 l/min
Absorption material	ZR gel 3-6 mm		
ZR gel	Non toxic		
Operating temp.**	-40... +90 °C		
Housing material	SAN (Styrene Acrylonitrile)		
FLUID COMPATIBILITY			
Mineral Oils: H, HL, HLP, HVLP	Ok		
HEES Synthetical ester	Ok		
Other fluids	contact RMF Systems		

HEAVY DUTY SERIES KL..R				
TYPE	KL93R (C)	KL96R (C), (V)*	KL121R (C), (V)*	KL122R (C), (V)*
Total weight	1.2 kg	1.5 kg	2.7 kg	4.0 kg
ZR gel volume	300 cc	600 cc	1.000 cc	2.000 cc
Water absorption	86 gram	172 gram	288 gram	576 gram
Max. air flow	700 l/min	700 l/min (300 l/min)	1.500 l/min (400 l/min)	1.500 l/min (400 l/min)
Absorption material	ZR gel 3-6 mm			
ZR gel	Non toxic			
Operating temp.**	-40... +90 °C			
Housing material	SAN (Styrene Acrylonitrile)			
Innercore	Stainless steel			
FLUID COMPATIBILITY				
Mineral Oils: H, HL, HLP, HVLP	Ok			
HEES Synthetical ester	Ok			
Other fluids	contact RMF Systems			

* C - Active coal, V - Check Valves

** Note that the operation of the desiccant breather may vary at temperatures below 0 °C due to very low humidity %.

SPIN-ON SPECIFICATION

PRODUCT DETAILS	KL60	KL90	KL120
Filter material	Glass fibre		
Housing material	Steel 0.50 DKP 7124		
Surface Area	415 cm ²	754 cm ²	2116 cm ²
Filter efficiency	$\beta_3 = 200$		
Dirt Holding Capacity	3,2 gram MTD	6,0 gram MTD	16,5 gram MTD

FLOW PRESSURE DIFFERENTIAL

CHARACTERISTIC FLOW PRESSURE DIFFERENTIAL KL60 SPIN-ON

FLOW (M ³ /H)	DIFFERENCES OF PRESSURE (MBAR)
19,0	19
36,0	21
57,0	23
76,0	24,5*

*Max. Pressure Differential (Clean Filter)

**Pump damages could become possible above red line!

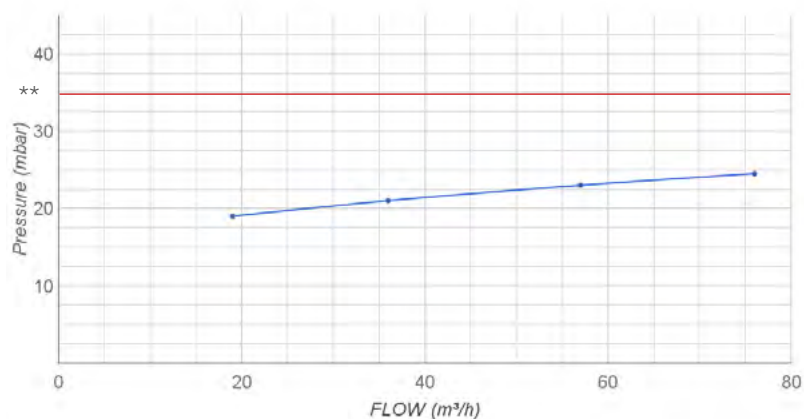

CHARACTERISTIC FLOW PRESSURE DIFFERENTIAL KL90 SPIN-ON

FLOW (M ³ /H)	DIFFERENCES OF PRESSURE (MBAR)
19,0	16
36,0	18
57,0	20
76,0	23
96,0	28*

*Max. Pressure Differential (Clean Filter)

**Pump damages could become possible above red line!

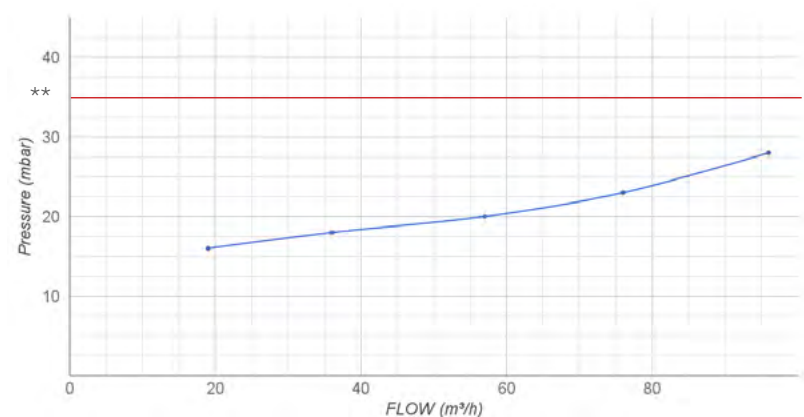

CHARACTERISTIC FLOW PRESSURE DIFFERENTIAL KL120 SPIN-ON

FLOW (M ³ /H)	DIFFERENCES OF PRESSURE (MBAR)
47,5	1,5
95,0	5,5
142,5	10
190,0	20
237,5	32*

*Max. Pressure Differential (Clean Filter)

**Pump damages could become possible above red line!

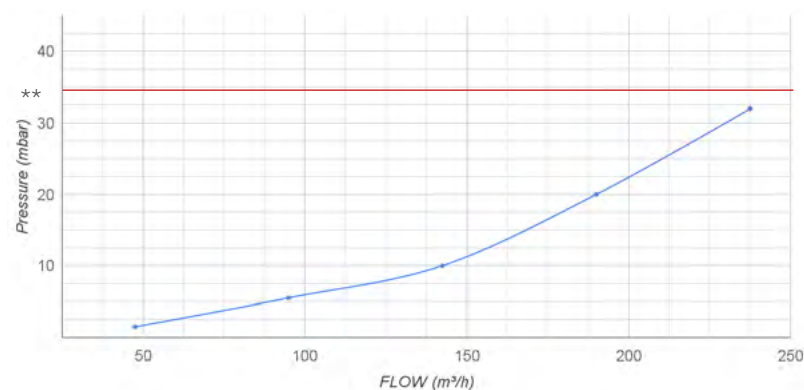

DIMENSIONS AIR CONDITIONERS

LIGHT VERSION SERIES ACL..R / ACM..R

DIMENSIONS	ACL93R (V)	ACL96R (C), (V)	ACM61R
L1	150 mm	210 mm	135 mm
Ø D	96 mm	96 mm	68 mm
G	¾" BSP female	¾" BSP female	¾" BSP female

HEAVY DUTY SERIES KL..R

DIMENSIONS	KL93R (C), (V)	KL96R (C), (V)	KL121R (C), (V)	KL122R (C), (V)
L1	155 mm	220 mm	250 mm	360 mm
L2	30 mm	30 mm	40 mm	40 mm
Ø D	96 mm	96 mm	128 mm	128 mm
G	¾" BSP male	¾" BSP male	1 ¼" BSP male	1 ¼" BSP male
AF	32 mm	32 mm	50 mm	50 mm

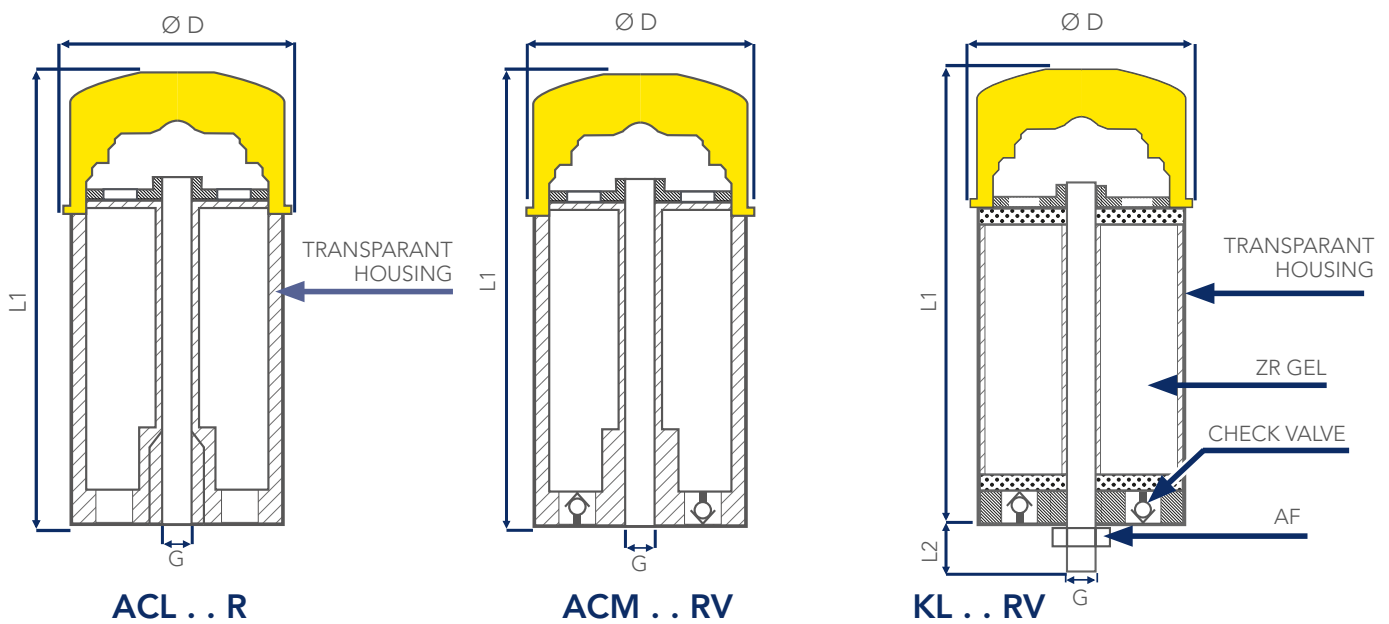

DIMENSIONS SPIN-ONS			
	KL60	KL90	KL120
H	60 mm	60 mm	100 mm
D	69 mm	98 mm	130 mm
T	M20x1,5	R ¾ BSP"	R 1 ¼ BSP"

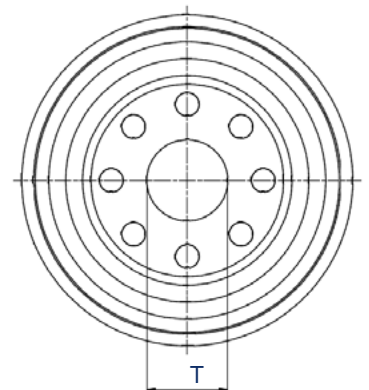
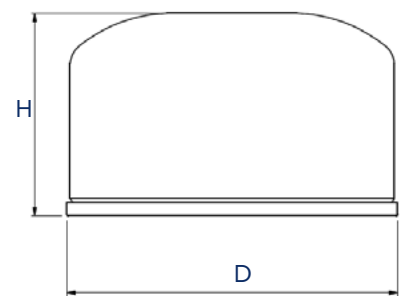

HYDRAULIC SYMBOL

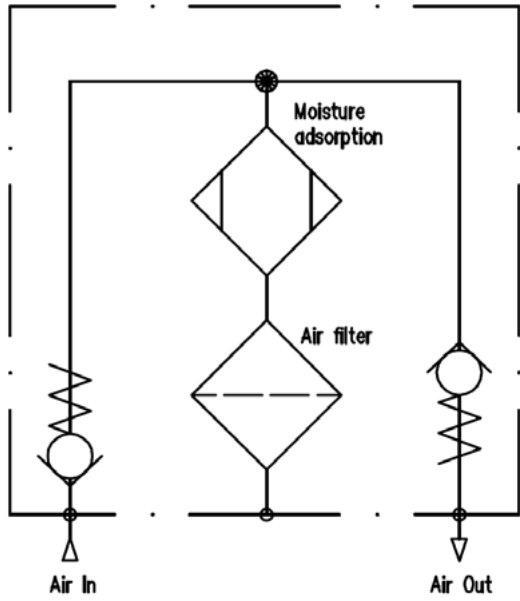

With check valves

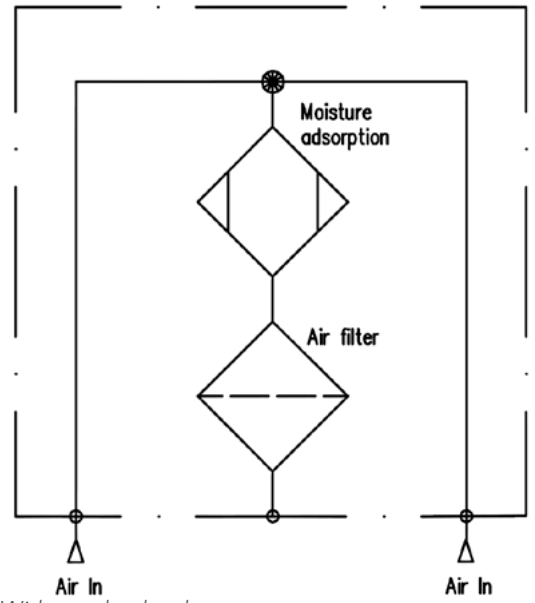

Without check valves

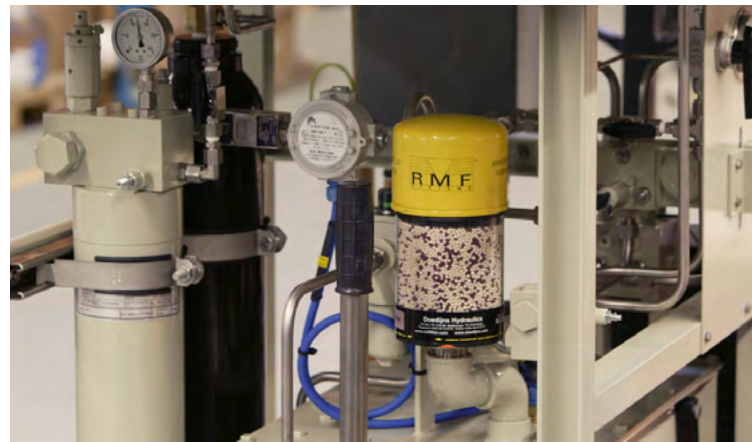
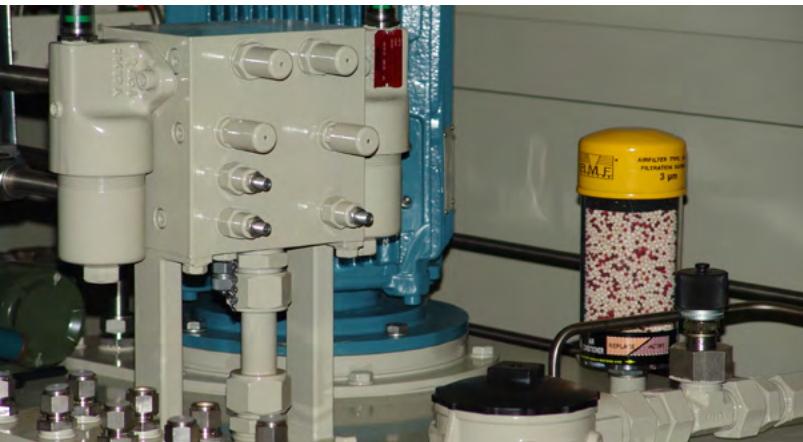

Air conditioners **Ordering codes**

YOUR AIRCONDITIONER ORDERING CODE

TABLE 1	TABLE 2	TABLE 3	TABLE 4

TABLE 1 - TYPE OF BODY			CODE
TYPE OF BODY	TANK CONNECTION	AIR FILTER	
Heavy duty version	Male threading on stainless steel tube	3μ fiber glass spin-on	KL
Light version (only in 93 and 96 series)	Female threading in plastic housing	3μ fiber glass spin-on	ACL
Mini light version (only in 60 series)	Female 3/8" threading in plastic housing with two integrated check valves (0.01 bar)	3μ fiber glass spin-on	ACM

TABLE 2 - SPECIFICATIONS						CODE
DIAMETER	HEIGHT	CONNECTION	WEIGHT	MAX. AIR FLOW STANDARD VERSION	RESTRICTED AIR FLOW WITH CHECK VALVES	
ONLY SUITABLE FOR KL SERIES						
Ø 96 mm	185 mm	3/4" BSP (male)	1.2 Kg	700 l/min	N.A.	93
Ø 96 mm	250 mm	3/4" BSP (male)	1.5 Kg	700 l/min	300 l/min	96
Ø 128 mm	290 mm	1 1/4" BSP (male)	2.7 Kg	1500 l/min	400 l/min	121
Ø 128 mm	400 mm	1 1/4" BSP (male)	4.0 Kg	1500 l/min	400 l/min	122
ONLY SUITABLE FOR ACL SERIES						
Ø 96 mm	150 mm	3/4" BSP (female)	0.9 Kg	700 l/min	N.A.	93
Ø 96 mm	210 mm	3/4" BSP (female)	1.1 Kg	700 l/min	300 l/min	96
ONLY SUITABLE FOR ACM SERIES						
Ø 68 mm	135 mm	3/8" BSP (female)	0.4 Kg	N.A.	50 l/min	61

TABLE 3 - SPECIFICATIONS				CODE
TYPE	DRYING AGENT	DESSICANT VOLUME	NOMINAL WATER ABSORBING CAPACITY	
61	ZR gel	100 cc	29 grams	R
93	ZR gel	300 cc	86 grams	R
96	ZR gel	600 cc	172 grams	R
121	ZR gel	1000 cc	288 grams	R
122	ZR gel	2000 cc	576 grams	R
93	Approx. 2/3 ZR gel, 1/3 active coal	200 cc / 100 cc	57 grams	RC
96	Approx. 2/3 ZR gel, 1/3 active coal	400 cc / 200 cc	115 grams	RC
121	Approx. 2/3 ZR gel, 1/3 active coal	700 cc / 300 cc	201 grams	RC
122	Approx. 2/3 ZR gel, 1/3 active coal	1400 cc / 600 cc	403 grams	RC

TABLE 4 - OPTIONS		CODE
No check valves		-
Integrated check valves (0.01 bar), not available for 93 series. Note: restricted airflow		V

Please note the following:

Installing an Air Conditioner with springloaded check valves may cause an over- or under pressure of approximately 0.01 bar (10mbar) inside the reservoir.

Oil-Demister Specifications

OIL-DEMISTER	140	210
DIMENSIONS		
	140x60 mm	210x60 mm
WEIGHT		
	1,03 kg	1,25 kg
CONNECTIONS		
	Base 3/4" BSP int.	Base 3/4" BSP int.
	Top 3/4" BSP or 1 1/4" BSP	Top 3/4" BSP or 1 1/4" BSP
MATERIAL		
Body	Anodized Aluminum	
Base adaptor	Steel	
Top adaptor	Steel	
Flow rate (air)	1000 l/min.	
OIL-DEMISTER CAPACITY		
	See diagram	

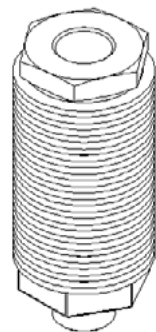
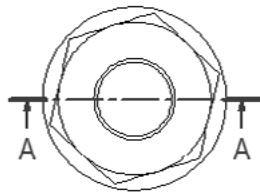
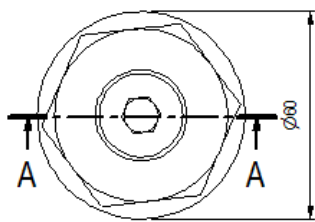

Type 140

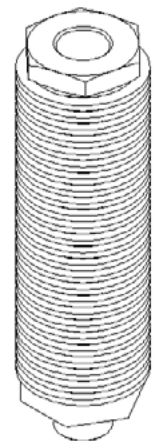

Type 210

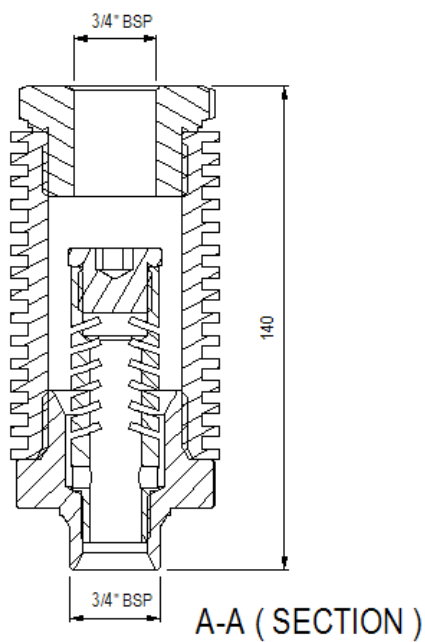

A-A (SECTION)

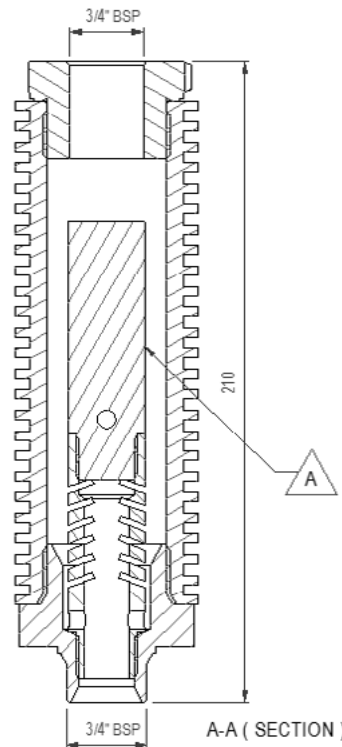

A-A (SECTION)

Airflow test into a tank

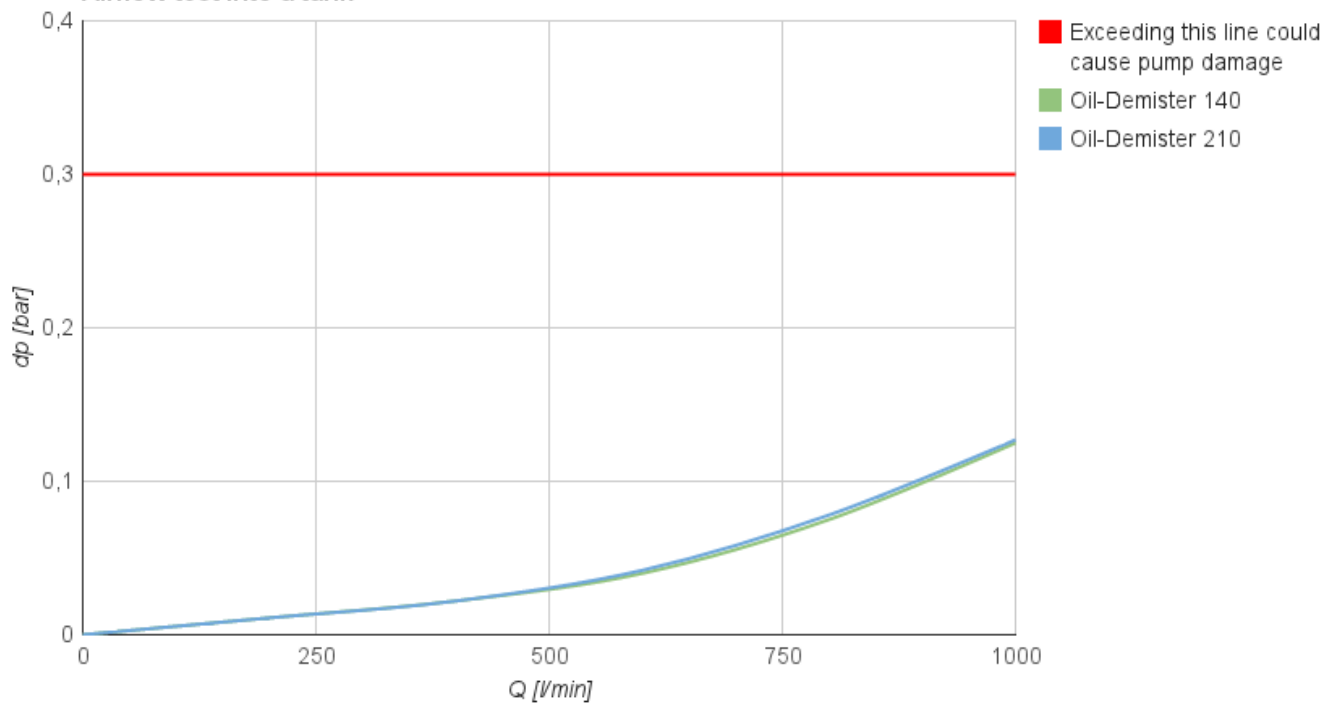

Airflow out of a tank

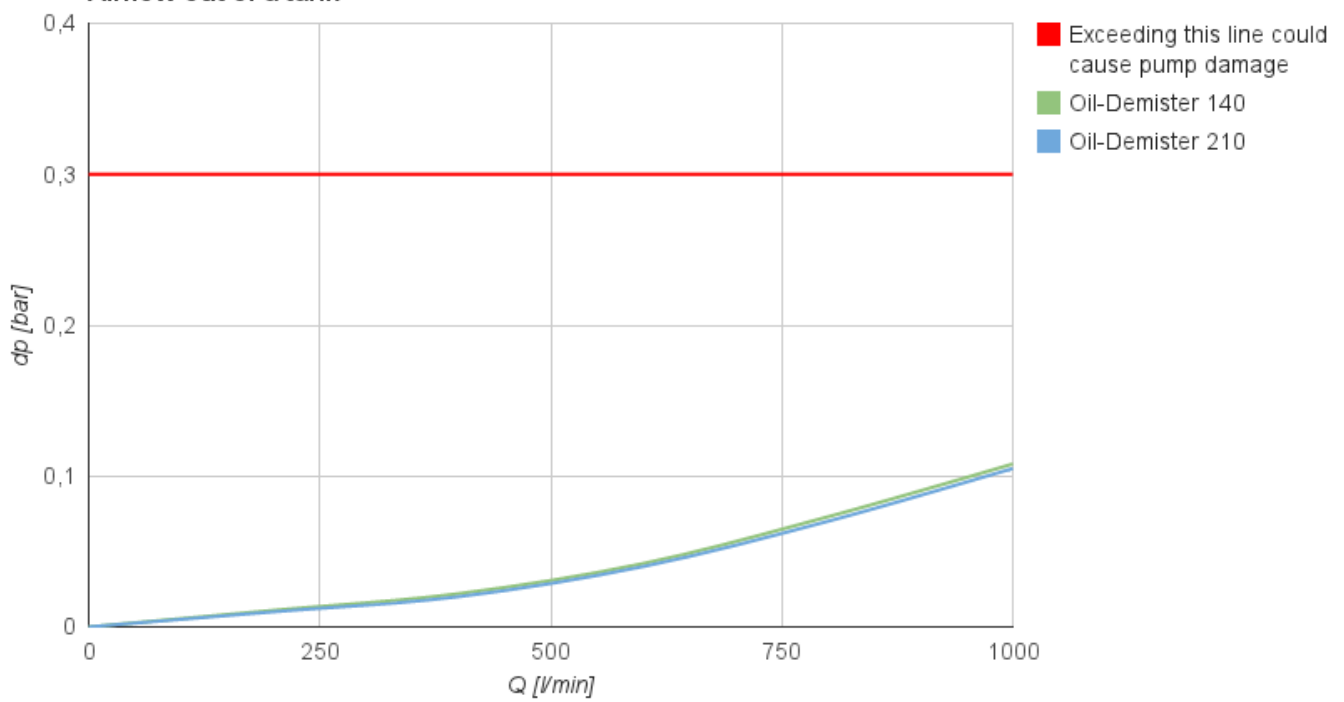

Ordering Code

AIR CONDITIONERS SPARE PARTS AND ACCESSORIES

ACCESSORIES DESCRIPTION	ORDERING CODE			
	ACL93 AND KL93 SERIES	ACL96 AND KL96 SERIES	KL121 SERIES	KL122 SERIES
Filter minder (indicator + electr. contact and nipple)	9331303			
Filter minder connector (w/o cable) for use with 9331303	9331320			
Mounting plate	KL92		KL1202	
Mounting plate + filter minder port	KL95		KL1205	
Mounting plate + filter minder port + return port	KL91		KL1201	
Mounting plate + filter minder port + suction and return port	KL91SR		N.A.	
Barrel Adapter	KL75		N.A.	
Pressurised Tank Adapter	KL98		N.A.	
Mounting plate with check valves	N.A.		KL1200V	
Oil-Demister small	140		N.A.	
Oil-Demister large	210		N.A.	
Pall to RMF Systems Adaptor	KL99		N.A.	

ACCESSORIES DESCRIPTION	ORDERING CODE			
	ACL93 AND KL93 SERIES	ACL96 AND KL96 SERIES	KL121 SERIES	KL122 SERIES
Air filter only	KL90 (incl. seal)		KL120 (incl. seal)	
ZR gel refill in air tight container	KL/ACL 93 series refill ZR gel 300 cc	KL/ACL 96 series refill ZR gel 600 cc	KL121 series refill ZR gel 1000 cc	KL121 series refill ZR gel 2000 cc
ZR gel refill in air tight container	Refill ZR gel 4000 cc			
Active coal refill in air tight container ¹	300 cc	300 cc	300 cc	600 cc
Spare kit including ZR gel, air filter, seal and foam pads	Spare kit KL93R/ ACL93R	Spare kit KL96R/ ACL96R	Spare kit KL121R	Spare kit KL122R

¹ Please note that smallest Active coal refill available is 300 cc container. To be used for 93, 96 and 121 series

Filter Minder Specifications

The graduated indicator monitors the airfilter. The position indicator progressively fills the window as the air filter restriction increases, looking at the highest restriction.

The airfilter should be changed when the position indicator reaches the red zone.



SPECIFICATIONS	
OPERATING TEMP.	-40° C to +120° C
MATERIAL	Polycarbonate Housing
STANDARD CALIBRATION	2 to 8,7 kPa
(VACUUM) FULL SCALE	5,0 kPa (20 IN.)
VACUUM FIRST MOVEMENT	1,5 kPa (6 IN.)
SWITCHING VOLTAGE	300 VDC Max.
VOLTAGE BREAKDOWN	450 VDC Max.
SWITCHING CURRENT	1,20 A Max.
CARRYING CURRENT	0,50 A Max.

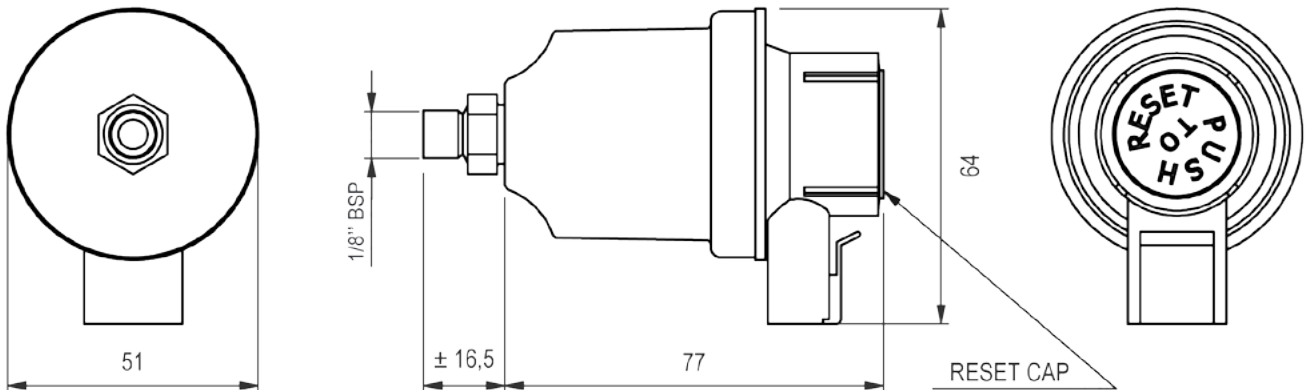

Mounting Plate Dimensions

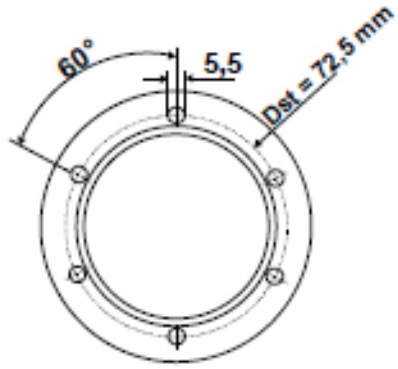

All mounting plates are drilled according pattern DIN 24557/2

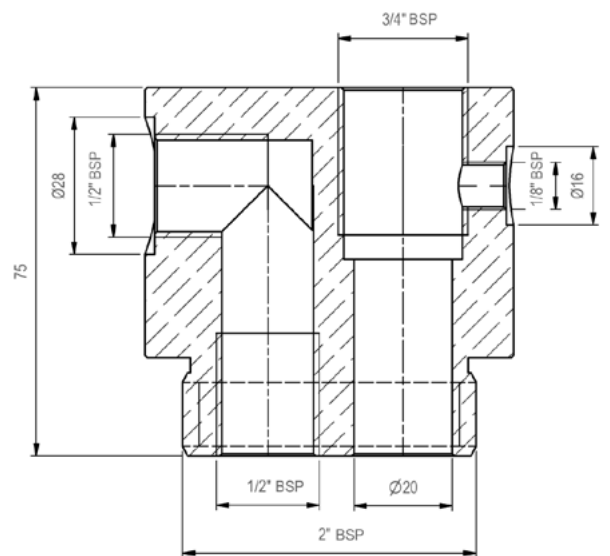
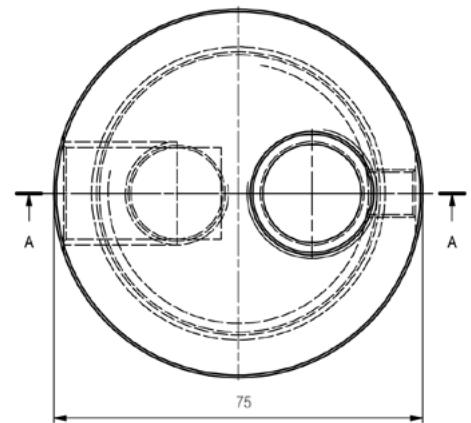
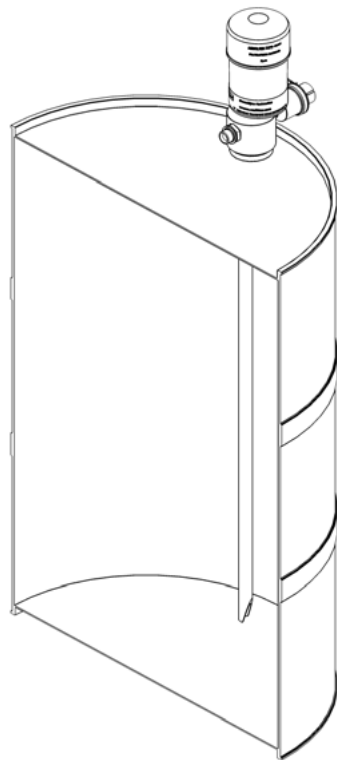
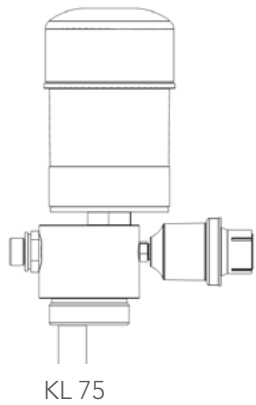

SECTION A-A

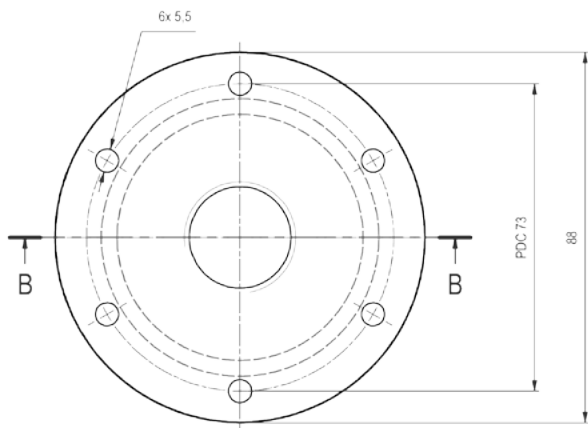
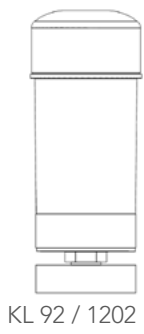

KL 92 / 1202

Section B-B

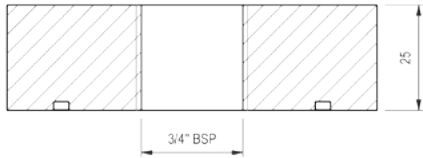

KL 92

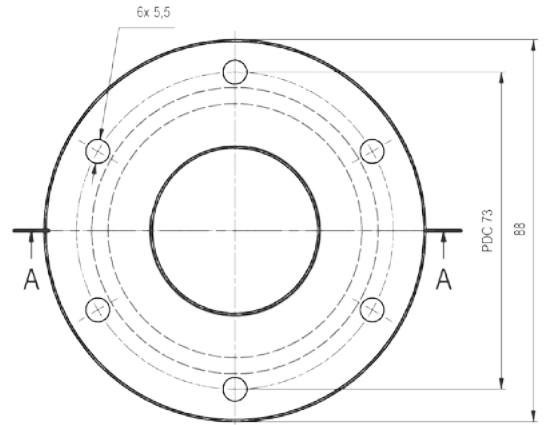

Section A-A



KL 1202

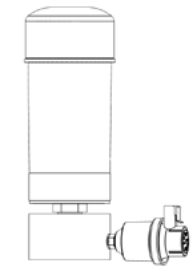

KL 95 / 1205

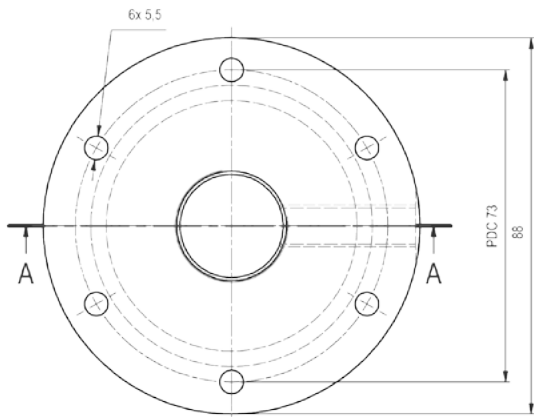

Section A-A

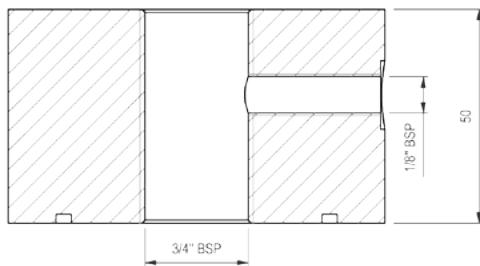

KL 95

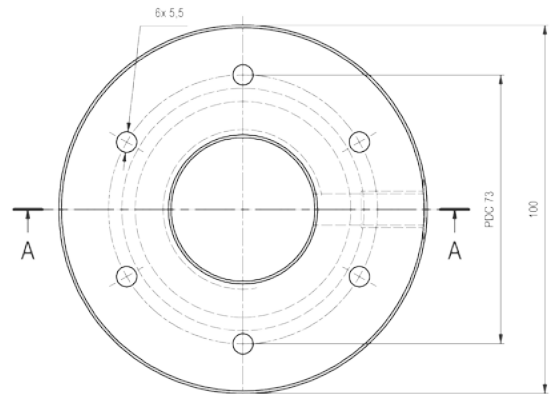

Section A-A

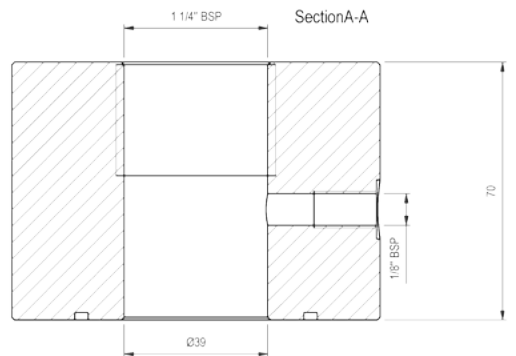

KL 1205

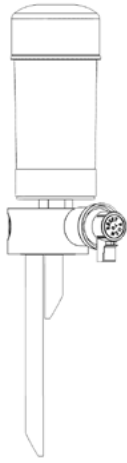

KL 91SR

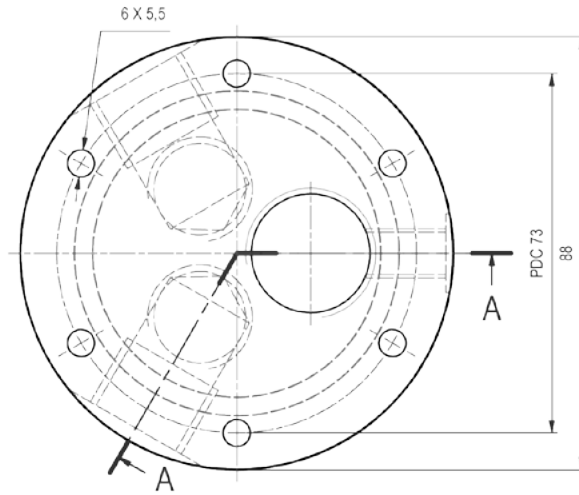

Section A-A

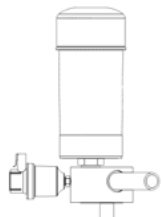
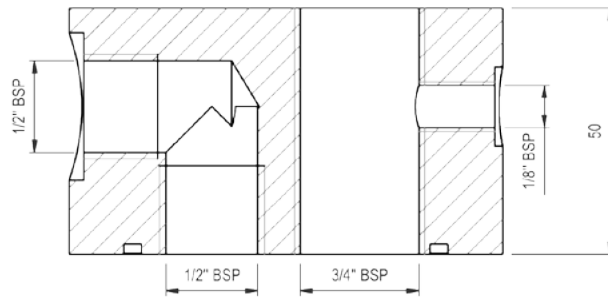

KL 91 / KL 1201

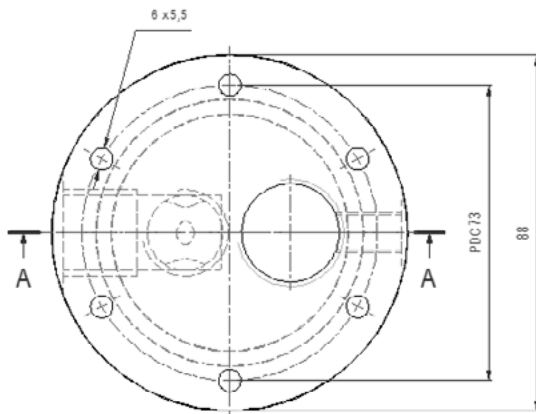

Section A-A

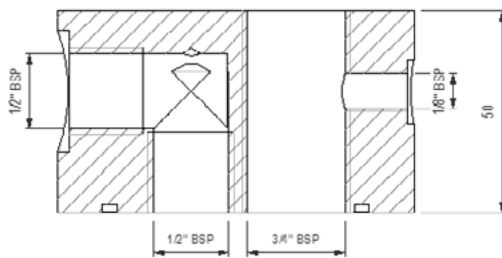

KL 91

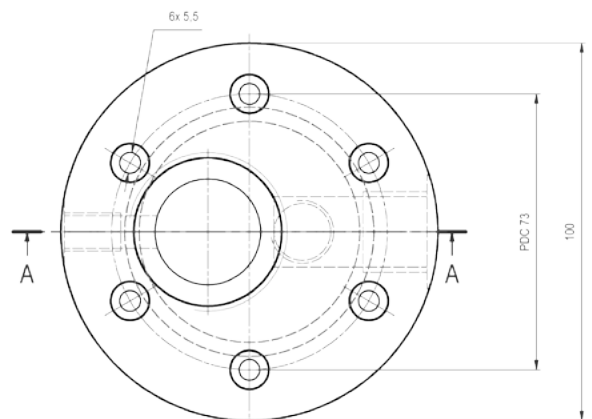

Section A-A

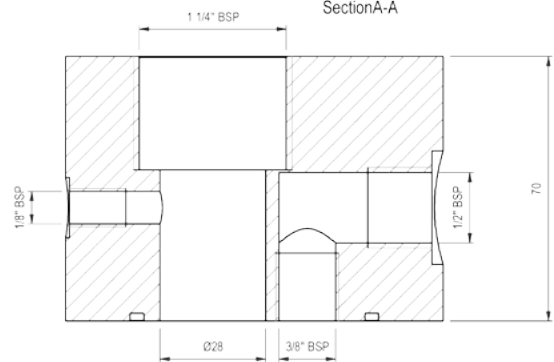

KL 1201



KL 98

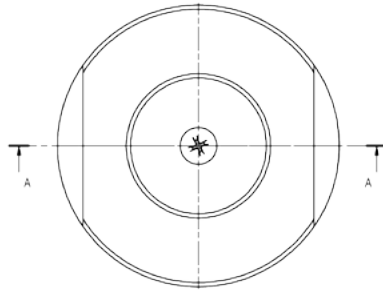

SECTION A-A

RMF AIR CONDITIONER CONNECTION

SW - 41

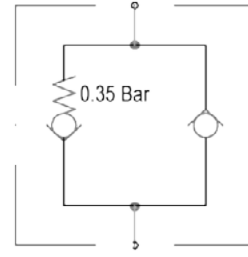
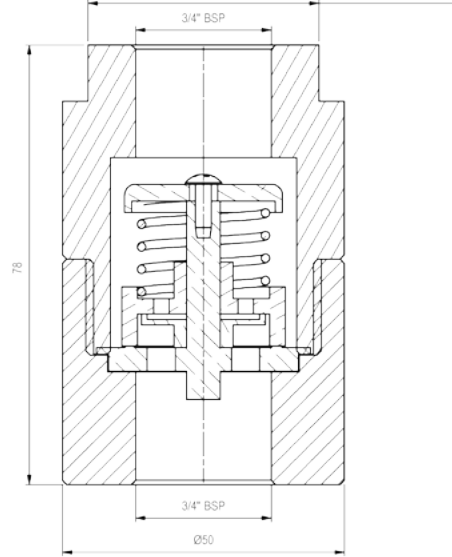

KL 1200V

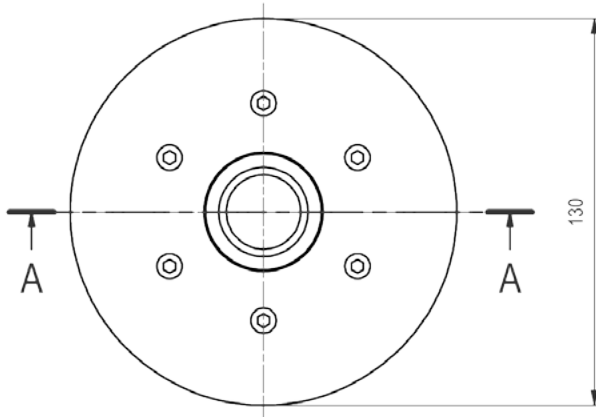

Section A-A

1 1/4\"/>

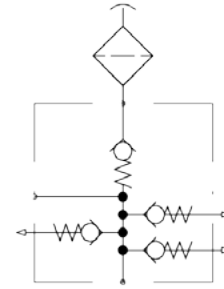
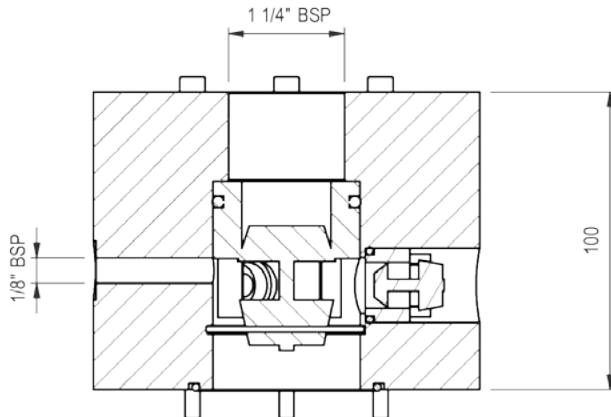

CHECK VALVE CRACKING
PRESSURE 0,01 - 0,02 BAR



We're Here To Help You

Coenecoop 71 | 2741 PH

Waddinxveen | The Netherlands

T (31) 182 30 28 88

F (31) 182 30 28 89

E info@rmffilter.com



SUBJECT TO CHANGE
WITHOUT PRIOR NOTICE

B_AIR CONDITIONERS_20150126_EN