

CARDEV®

Product Datasheet

SDU-M8

By-pass Filter for engine oils

- Up to 99.9% water removed (both free and dissolved water)
- Particle contamination (including combustion deposits) removed
- Oil life can be extended by up to 4 times



Benefits

- Removes microparticles including combustion deposits
- Removes free and dissolved water contamination
- Increases system reliability
- Prevents system corrosion
- Reduces component wear
- Extends oil life and generates CO₂ saving
- Reduces operating costs

Application Examples

Diesel engines in applications such as:

- Earth moving machines
- Forestry equipment
- Rail maintenance machines
- Drilling/piling equipment
- Marine
- Gensets
- Truck and Bus fleets

Installation Example

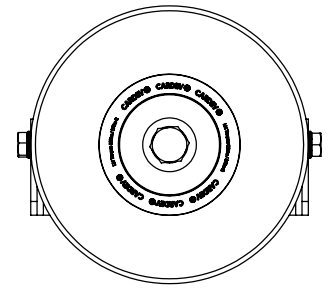
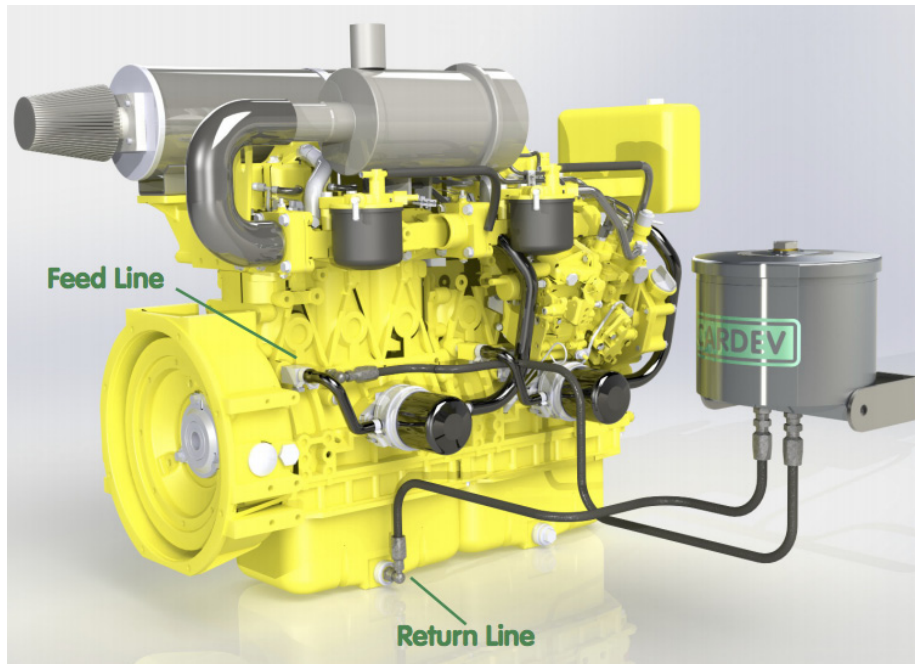

Ø 217mm

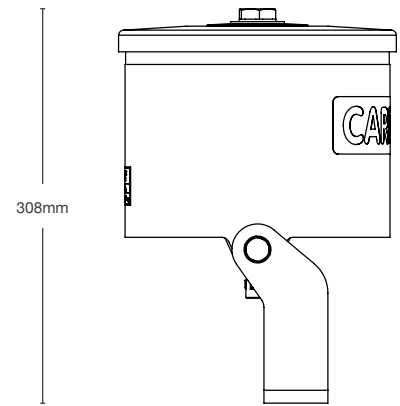

308mm

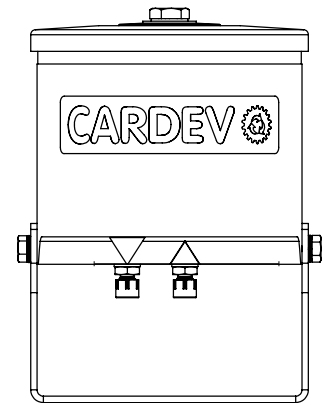

Recommended installation	Flow Rate (l/h)	Dimensions (mm)		Weight (kg)	Filter Element Type	Retention Capacity (per set)	
		H	D			≤ 2.5 kg Dirt (kg)	≤ 0.78 Litres of water
BY-PASS ONLY. Max input pressure 2-6 Bar and 0.5 bar back pressure. Systems up to 40 l and/or 400 KW	120-240 (Max)	303	Ø 217	8	Standard fit: 1 x SDFC	≤ 2.5 kg Dirt (kg)	≤ 0.78 Litres of water

ETL FluidExperts

ETL Fluid Experts Ltd
 Environmental Technologies Group Grimbald Crag Road Knaresborough North Yorkshire HG5 8PY United Kingdom
 T +44 (0)1423 522911 F +44 (0)1423 530043 E sales@etlfe.com

www.etlfluidexperts.com

The specification and photography is for reference only and may be subject to change.
 ETL Fluid Experts Ltd is part of the Environmental Technologies Group Ltd. All rights reserved.