



# Loading Systems Catalog

Safer. Cleaner. Faster.



**OPW**   
ENGINEERED SYSTEMS  
A  DOVER COMPANY

[www.opw-es.com](http://www.opw-es.com)





OPW Engineered Systems specializes in the engineering, designing and manufacturing of systems for the safe and efficient loading and unloading of critical hazardous materials: loading systems, swivel joints, instrumentation, quick and dry disconnect systems and safety breakaways.

# Table of Contents

**Loading Arm Design Considerations .....4-5**

**Bottom Loading Systems ..... 6**

- Unsupported Boom-Type Bottom Loader.....7
- “A” Frame Loader Arm .....8
- “A” Frame Hose Loader Arm.....9
- CWH Series Counterweighted Hose Loader ..10
- Spring Balanced Hose Loader .....11
- 1004D3 and D4 Bottom Loading Couplers ....12

**Top Loading Systems.....13**

- Single-Arm Fixed Reach .....14
- Scissor-Type Arm.....15
- Supported Boom Arm .....16
- Unsupported Boom Arm.....17
- Slide-Sleeve Arm .....18

**Vapor-Recovery Loading Arms ..... 19-21**

- Top-Loading Vapor-Recovery Systems ..... 20-21

**Custom Applications.....23**

- Steam-Jacketed Loading Arms .....24
- Custom Insulation Packages .....25
- Scissor, Boom, By-Pass Loading Arms and Drum Filling .....26
- Pneumatic-Controlled Loaders .....27
- Loading Rack Hose Covers, Deflectors and Strainers .....28

**System Components**

- Swivel Joints.....29
- Counterbalance Units..... 30-31
- Safety Breakaway Devices..... 32-33

**System Components (continued)**

- Dry Disconnects, Vacuum Breakers and Loading Valves.....34
- Rack Monitoring Equipment
  - Diagnostic Opti-Therm 8580 Series .....35
  - 8460 Opti-Therm Overfill Detection System.....35
  - Opti-Therm Scully® Replacement Chassis...35
  - Thermistor Rack Monitors 8300 Series...36
  - Optic Rack Monitors 8130 Series.....36
  - Ground Verification Monitor 8030 Series .....37
  - Cane Probes, Plugs and Cord Sets .....37
  - Valve Actuators .....37
- Floating Suction Assemblies
  - Internal Tank Floating Roof Drain Assemblies.....38
  - 763/764/765/766 Series .....39



Autolok™, Drylok™, Twin-Kam, Endura, GFL, Cliplok and Spring Ring are trademarks, and OPW®, VISI-FLO®, Kamvalok® and Kamlok® are registered trademarks of OPW Engineered Systems. Hastelloy® is a registered trademark owned by Haynes International, Inc. Viton® and Kalrez® are registered trademarks of DuPont Dow Elastomers. Teflon® is a registered trademark of DuPont. Chemraz® is a registered trademark of Green Tweed. Scully® and BICLOPS® are registered trademarks of Scully Signal Co.

OPW Engineered Systems is dedicated to listening closely to the needs of our customers and to providing high-value solutions that deliver safer, cleaner, faster methods of fluid handling. OPW Engineered Systems is committed to the design and manufacture of high-quality, reliable products and the highest levels of responsiveness and customer service. OPW combines 116 years of industry leadership, product innovation, and sales and distribution expertise to help educate people on the “better, more responsible way” to handle hazardous bulk liquids.

## Overview

### Introduction

OPW Engineered Systems offers the most complete line of equipment to meet the demands of today’s loading and unloading requirements. Whether you’re transferring petroleum products, liquefied gases, asphalt, solvents or hazardous, corrosive chemicals to or from tank trucks, railcars, drums or totes, OPW can help.

### Proven Experience & Flexibility

Experience and versatility are cornerstones of OPW’s 116-year leadership position. Systems are logically designed solutions to meet everything from modest drum-filling demands to sophisticated, high-volume custom-designed top and bottom-loading configurations.

### Safety, Efficiency & Ease of Operation

Each OPW system is designed with personnel and environmental safety as the top priorities, followed by maximum efficiency. Each system is built to meet specific application requirements, such as flexibility, physical limitations, personnel preference, operating experience, compliance regulations, vehicle sizes, types and attachments. Loading systems are highly engineered and rigorously tested to ensure the highest levels of safety and quality throughout production and operation. Additionally, systems are:

- **Self Organizing (self-contained and space-efficient)**
- **Environmentally Friendly (retract out of the way to eliminate potential hazards due to hose run-overs)**
- **Health-Friendly (self-supported, precision-engineered to eliminate strenuous lifting or moving)**

OPW loading systems are available in many configurations and sizes. Superior design provides maximum safety, efficiency and operational benefits:

- **Ease of operation**
- **Adequate horizontal and vertical range**
- **Adequate capacity without excessive pressure drop**
- **Ease of maintenance**
- **Materials adequate for the service – metals, seals and gaskets that are chemically compatible with the products being handled, as well as transfer temperatures and prevailing climatic conditions**

### Bottom Loading Advantages

- **Personnel safety advantages – people stay on the ground**
- **Reduction in static build-up during loading**
- **Reduction in vapors**
- **Improved loading efficiency**
- **Cost savings relative to rack construction**

### Service & Support Beyond Compare

OPW Engineered Systems provides in-depth technical assistance from the initial design phase through installation and beyond. Internal and external sales teams are knowledgeable about products and skilled in solving your transfer problems. Highly personalized professional service, site evaluations, design and applications engineering expertise and meticulously engineered and exceptionally built products ensure your complete satisfaction.

**OPW continually strives to maintain their leadership position in the industry by responding to your needs and supplying the high-quality, dependable products you require.**



**1 System Design Tips**  
 Line Sizing: As a general rule, it is recommended that the line velocity not exceed 15-20 ft/second (4.6 to 6.1 m/sec). The chart (right) shows recommended flow rates for different line sizes.

Line Size	Maximum Flow Rate by Line Velocity	
	15 ft. per second	20 ft. per second
2	150 GPM (568 LPM)	200 (757)
3	350 GPM (1,325 LPM)	450 (1,703)
4	600 GPM (2,271 LPM)	800 (3,028)
6	1,350 GPM (5,110 LPM)	1,800 (6813)

**2 Plant Piping Orientations**  
 Several options are available depending on the plant-piping configuration.

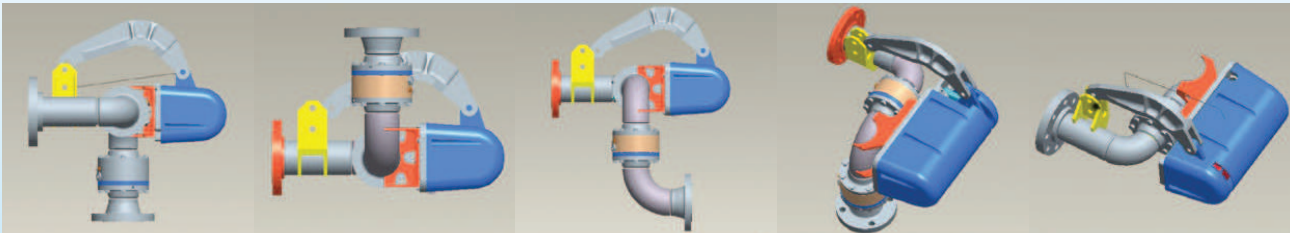

**Upfeed      Downfeed      Horizontal Feed      Right Handed      Left Handed**

**3 Materials**  
 Materials and seals must be generally compatible with the product and its temperature during handling. Materials will typically match plant piping on which the arm is installed.

- Metals (standard): carbon, steel, stainless steel, aluminum
- Seals (standard): Fluorocarbon, Buna-N, PTFE, EPDM and Neoprene
- Piping: Schedule 10, 40, 80, seamless or welded, all flanged

**4 Added Weight**  
 Adding or reducing weight on an arm will affect the arm's balance. Please specify all weight that will be added to or taken off arm when installed. Common additions include:

- Insulation
- Valving
- Vapor Recovery Lines
- Product Being Stored in Arm

**5 Other Considerations:**  
**Valving** – Valves are a commonly specified option. Specific valves can be provided to meet your needs. Note location and type of valve required.

**Steam Tracing** – Loading arm can be easily designed to incorporate partial or full steam jacketing.

**High Level Shut-Off** – Several options are available to help ensure that overflow conditions are prevented.

**Grounding** – Another important consideration when loading volatile products – several options are available to help ensure system is properly grounded.

**Adequate Range of Motion**

- Can arm be easily accessed/stored?
- Any possible interference/obstacles?
- Adequate Flexibility to make connection?
  - Structural Steel
  - Overhead Pipe Access Equipment



**Termination Connections**



**Autolok™**

- Provides extra protection against accidental release or uncoupling
- Arms lock automatically with a positive click
- If our exclusive Twin-Kam™ arms ever break, they are replaced FREE



**Kamvalok®**

- Economical cam and groove dry-disconnect coupler
- Prevents spillage at point of connection/disconnection
- Lever action closes flow at both ends of connection



## Counterbalance

Materials and seals must be generally compatible. A properly balanced loading arm will allow operators to move the arm into and out of the loading position effortlessly and safely.

### 790 Torsion Spring

- Safe, Easy Spring Adjustment
- Self Contained and Space Efficient
- Wide Range of Motion
- No Special Tools Required

### Pneumatic Cylinder

- Ideal for Heavy Load Applications
- Eliminates Strenuous Pushing, Pulling, or Lifting
- Push-Button Pendant Controller

### Inlet Connection

- Typically 150-pound flange
- Some applications may require 300-pound flange

## Swivel Design

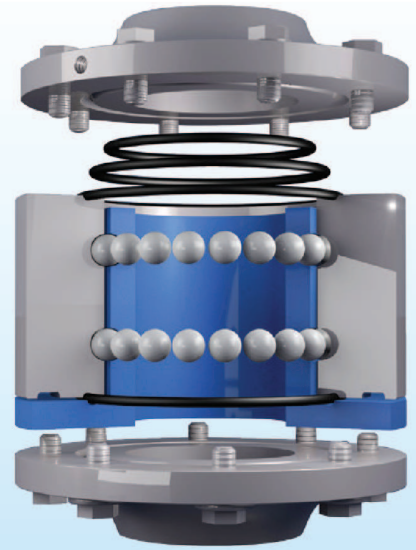

### 8000 Dual Split Flange (DSF) Series

- Best Available Swivel Technology
- Designed Specifically for Chemical/Industrial Loading Arms
- Redundant Sealing
- Easy Maintenance
- Leak Detection/Containment

### 3000 Series

- Conventional Radial O-Ring Design
- Typical in Petroleum/Lighter Load Applications



### DryLok™

- Driest disconnect in the industry (less than 1cc from 3" fitting)
- Ideal for high-pressure applications
- 360° orientation ensures seating and alignment
- Rugged design ideal for loading rack



### NTS Series Breakaway

- Added Protection of People, Equipment and the Environment
- Durable and Reusable
- High Flow Rate



**IMPORTANT:** OPW products should be used in compliance with applicable federal, state, provincial, and local laws and regulations. Product selection should be based on physical specifications and limitations and compatibility with the environment and materials to be handled. OPW MAKES NO WARRANTY OF FITNESS FOR A PARTICULAR USE. All illustrations and specifications in this literature are based on the latest product information available at the time of publication. OPW reserves the right to make changes at any time in prices, materials, specifications and models and to discontinue models without notice or obligation.

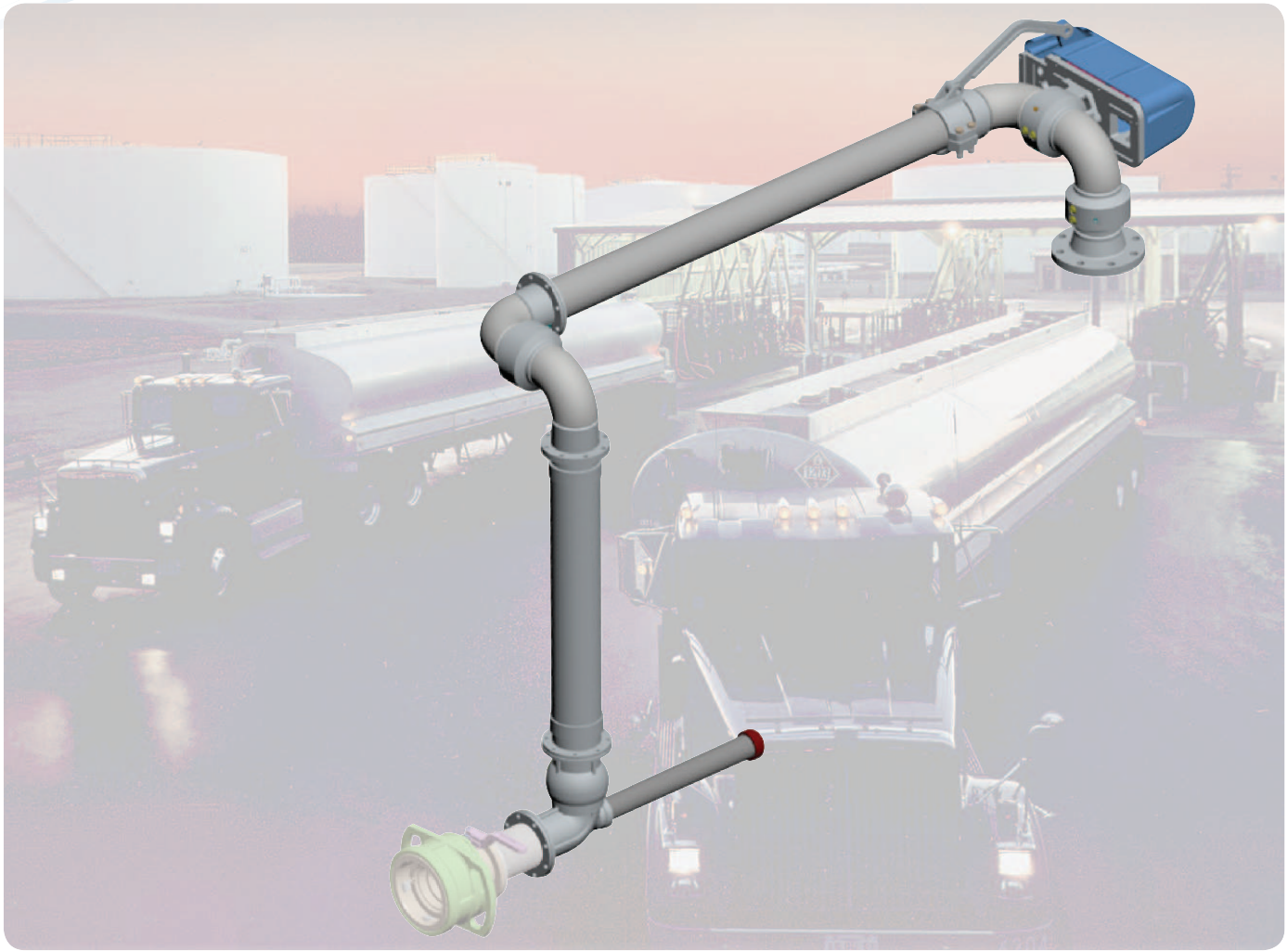

## Bottom Loading Overview

**OPW Engineered Systems Bottom-Loading Systems** offer numerous benefits over conventional top loading:

- Safety of the person operating the loading arm is the primary advantage; operator remains on the ground, not on top of the vehicle, the source at which falls commonly occur.
- Connections are made more quickly, thus reducing overall loading time.
- Bottom loading systems create less turbulence in the tank, reducing the danger of generating static electricity.
- Bottom loading not only reduces vapors, which can be an environmental hazard, but this system also can be easily adapted to fully recover vapors displaced during loading.

- Speed is a key advantage of bottom loading; tanks can be filled faster and a number of compartments can be loaded simultaneously.
- Bottom loading islands are simpler and cheaper to build than top loading racks. You can realize more savings because you'll safely load more material in less time, with less spillage and vapor loss.

OPW Engineered Systems offers a complete line of equipment that permits the efficient loading and unloading of petroleum products, chemicals, and liquefied gases.

## Unsupported Boom-Type Bottom Loader

Designed to provide flexible long-range operation, this heavy-duty configuration is both reliable and easy to use. A minimum of five swivel planes of rotation offer complete flexibility in making tight connections for loading and unloading railcars and tank trucks, and servicing aviation refuelers. The outboard swivel and arm adjusts for any changes in elevation or tilting that may result as the vehicle is loaded or unloaded.

The unsupported boom-type loader is extremely versatile and many variations are possible. It can be equipped with dry-disconnect coupler, union, quick coupling, or other customer-specified end fitting to make connections on the side, at the rear, or underneath the vehicle. The intermediate swivel is often inverted to achieve the low profile and clearances needed to connect to the underside of a railcar.

Typically installed at or near ground level, arms of varying lengths can be mounted on staggered risers to achieve crossover and neat compact storage of multiple arms in a confined space.

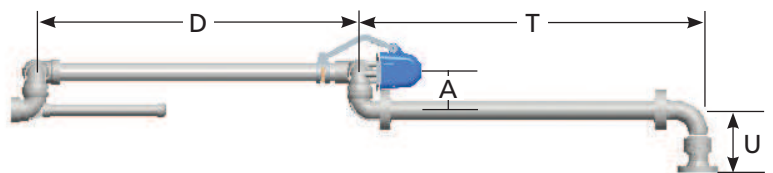
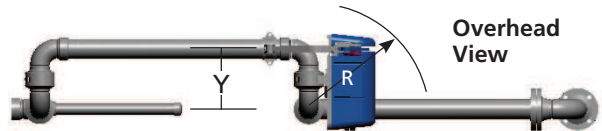
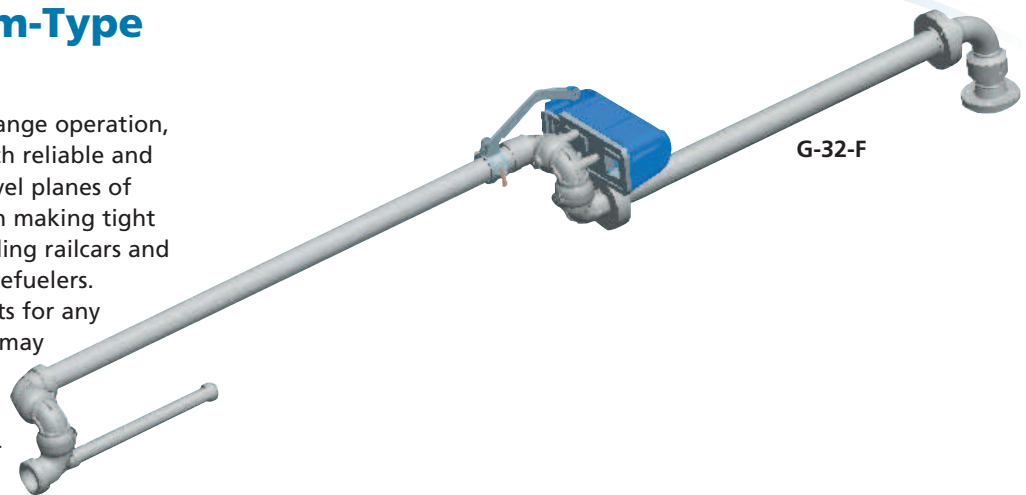

### Benefits

- Easy to operate/maneuver
- Accommodates changes in elevation
- Can be stored safely to ensure safe clearance of vehicles
- Easy to connect under the vehicle
- Very flexible to compensate for vehicle misplacement
- Scissor-back storage means no wasted space

### Features

- Low profile
- Long reach
- A minimum of five planes of rotation
- Compact storage
- Torsion-spring balanced
- Outboard two-plane swivel joint
- Available in 2", 3", 4" and 6"
- Available in steel, stainless steel, aluminum and specialty alloys
- Choice of flanged, threaded or all-welded construction

### Dimensions\*

Size	A		D		T		U		R		Y			
	in.	mm	in.	mm	in.	mm	in.	mm	in.	mm	in.	mm		
2"	51	1302	8-1/8	206	66	1676	42	1067	8-5/8	219	17	432	8-1/8	206
3"	76	1930	10-3/4	273	66	1676	42	1067	10-1/2	267	18-1/2	470	10-3/4	273
4"	102	2591	12-3/4	324	66	1676	42	1067	11-3/4	298	20	508	12-3/4	324
6"	152	3861	21-1/2	546	66	1676	42	1067	19	483	24-3/4	629	18-1/2	470

\*Custom dimensions also available.

**IMPORTANT:** OPW products should be used in compliance with applicable federal, state, provincial, and local laws and regulations. Product selection should be based on physical specifications and limitations and compatibility with the environment and materials to be handled. OPW MAKES NO WARRANTY OF FITNESS FOR A PARTICULAR USE. All illustrations and specifications in this literature are based on the latest product information available at the time of publication. OPW reserves the right to make changes at any time in prices, materials, specifications and models and to discontinue models without notice or obligation.



## "A" Frame Loader M-32-F

The "A" Frame is one of the more popular loading arm configurations. It provides good flexibility, long reach, and is convenient and easy to use. It adjusts for any changes in the elevation or tilting of the vehicle during loading or unloading. The arm stores neatly in the upright, near-vertical position, allowing it to swing around easily for loading from either side of the island.

The "A" Frame's compact storage envelope also allows these arms to be installed relatively close together, often on risers that are approximately the same height as the vehicle connection. They can also be mounted next to one another on staggered risers to achieve arm crossover for simultaneous loading of multiple compartment trucks.

Commonly used for tank-truck bottom loading, "A" Frame arms also can be used in top-loading and unloading installations. They are generally equipped with a dry-disconnect coupling, union, or other tight-fill fitting.

300-pound inlet flange and seamless piping are suitable for handling liquefied petroleum gases, including propane and butane.

### Benefits

- Easily stored away from vehicles
- For multiple product applications, it can be mounted close to another arm
- Can be stored safely to ensure safe clearance of vehicles
- Crossover easily can be achieved

### Features

- Low riser mounting height
- Available in 2", 3" and 4"
- Available in steel, stainless steel, aluminum and specialty alloys
- Choice of flanged, threaded or all-welded construction
- LPG service arms (LPG-32-F): all-welded construction
- Welded assemblies in steel and stainless steel with 300-lb. flanges

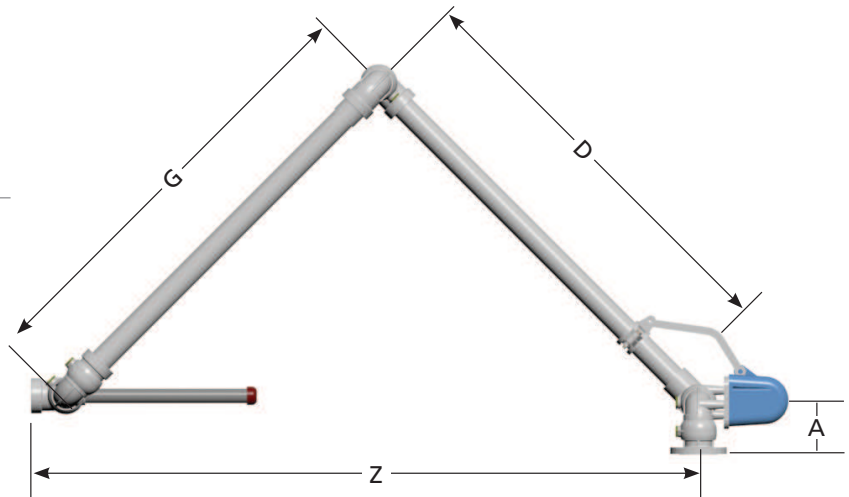
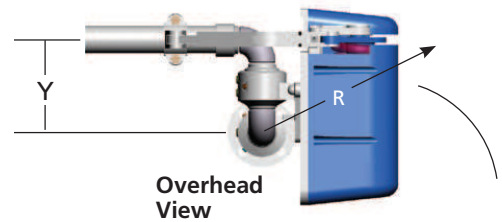

### Dimensions\*

Size	A		D		G		Z		R		Y			
	in.	mm	in.	mm	in.	mm	in.	mm	in.	mm	in.	mm		
2"	51	1300	8-5/8	219	60	1524	60	1524	90	2286	17	432	8-1/8	206
3"	76	1930	10-1/2	267	60	1524	60	1524	90	2286	18-1/2	470	10-3/4	273
4"	102	2590	11-3/4	298	60	1524	60	1524	90	2286	20	508	12-3/4	324

\*Custom dimensions also available.

## "A" Frame Hose Loader AFH-32-F

This spring-balanced hose loader offers the same advantages as the conventional "A" Frame arm, except flexible hose is used instead of rigid piping on the secondary arm.

Mounting heights for this style arm are shorter than those required for other hose loaders. This arm can be staggered to achieve crossover and conformance to the API envelope requirements. "A" Frame hose loaders are normally stored in an upright, near-vertical position, making it possible to load from both sides of the island.

In addition to bottom loading, the "A" Frame hose loader often is used as a vapor arm in fuel terminals and can be adapted for use in top-loading and unloading applications.

Minimum recommended drop hose length is approximately 60".

### Benefits

- Use as a vapor arm
- Easily stored away from vehicles
- For multiple product applications, it can be mounted close to another arm
- Can be stored safely to ensure safe clearance of vehicles
- Crossover easily can be achieved

### Features

- Low riser mounting height
- Available in 2", 3" and 4"
- Available in steel, stainless steel, aluminum and specialty alloys
- Choice of flanged, threaded or all-welded construction



"A" Frame hose loaders can also be ideal for some top loading applications.

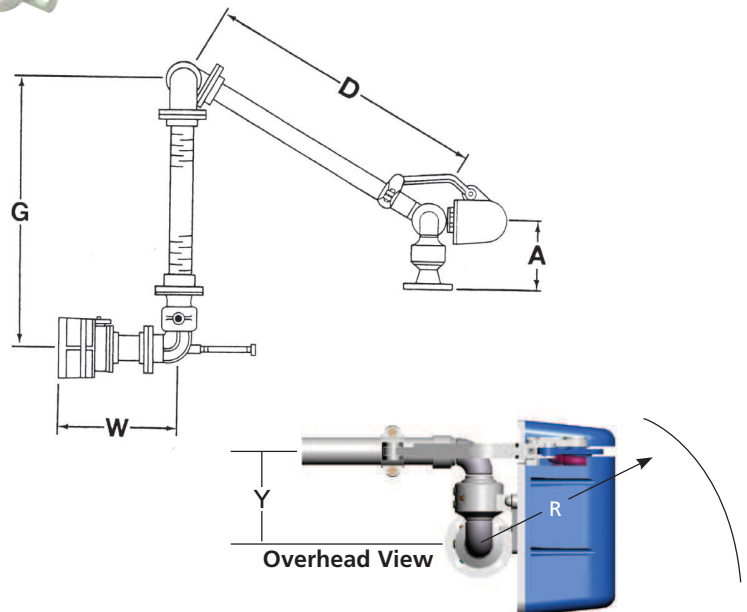

### Dimensions\*

Size	A		D		G		W		R		Y		
	in.	mm	in.	mm	in.	mm	in.	mm	in.	mm	in.	mm	
2"	51	8-5/8	219	60	1524	72	1829	15	381	17	432	8-1/8	206
3"	76	10-1/2	267	60	1524	72	1829	21	533	18-1/2	470	10-3/4	273
4"	102	11-3/4	298	60	1524	72	1829	21	533	20	508	12-3/4	324

\*Custom dimensions also available.

**IMPORTANT:** OPW products should be used in compliance with applicable federal, state, provincial, and local laws and regulations. Product selection should be based on physical specifications and limitations and compatibility with the environment and materials to be handled. OPW MAKES NO WARRANTY OF FITNESS FOR A PARTICULAR USE. All illustrations and specifications in this literature are based on the latest product information available at the time of publication. OPW reserves the right to make changes at any time in prices, materials, specifications and models and to discontinue models without notice or obligation.

## CWH Series Counterweighted Hose Loader

Installation and operation are simple and efficient with OPW Engineered Systems' hose loaders. Adjustable counterweights mounted on a pair of horizontal rails are simply moved until the desired balance point is located. This design provides for efficient handling and coupling to the tank adaptors.

This popular hose loader features a flange-by-flange base swivel joint for reliable performance and ease of maintenance. A heavy-duty Endura™ split flange base swivel joint is standard on 4" arms. Construction is carbon steel with a drop hose for maximum flexibility and easy handling. Composite hose (standard) and stainless-steel hoses are available. Outboard swivel joint, spacer spool and API coupler are aluminum on the standard model.

Standard horizontal reach is 114" to fully cover the API RP-1004 bottom-loading envelope, with up to four loading arms spaced 18" apart. Each loader should be mounted successively higher; 16" stagger is recommended to provide maximum crossover capability for efficient simultaneous compartment loading.

Optional reaches of 66", 78", 90" and 102" are also available, but full coverage of the API envelope may require moving the truck. Minimum recommended drop hose length is approximately 60".

### Benefits

- Easily meets envelope requirements
- Counterbalance adjustment is smooth and easy
- Multiple-compartment loading capability saves time
- Simple, rugged construction

### Features

- Crossover capability to meet API envelope
- Long reach
- Available in 4" sizes

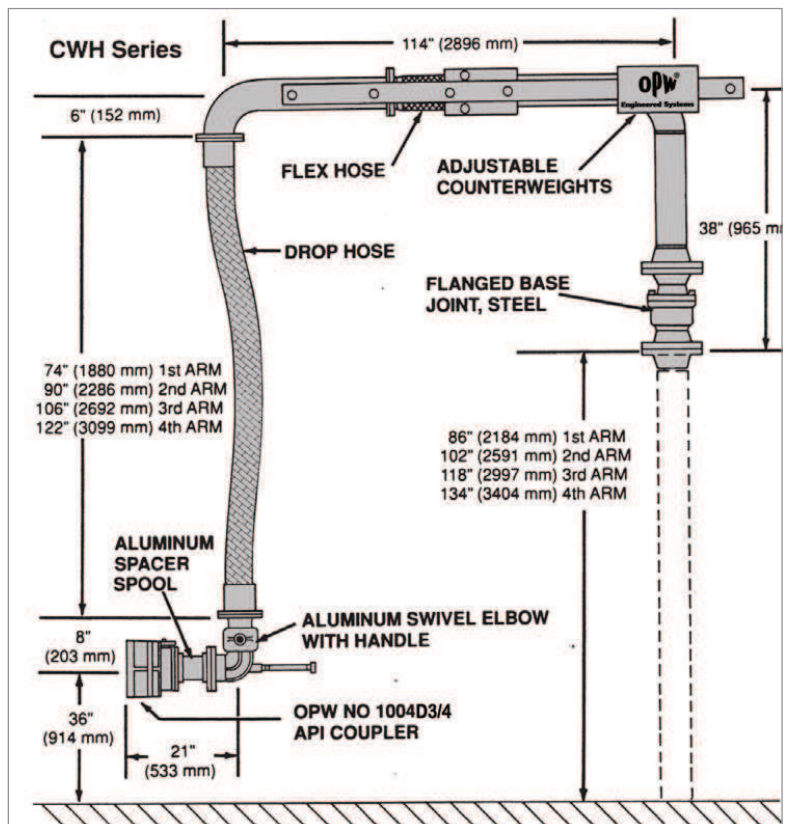



## Spring Balanced Hose Loader

Short Range SRH-32-F  
Long Range LRH-32-F

OPW Engineered Systems' spring-balanced hose loaders are available in both short-range and long-range versions. The short-range model has the torsion spring mounted back at the riser, while on the long-range units, the spring is located a short distance out on the arm. Like counterweighted hose loaders, spring-balanced hose loaders generally are stored horizontal and only slightly upward or downward movement is required to align the coupler with the tank truck adaptor.

This type of arm, in the 4" size, is used in exactly the same manner as the counterweighted hose loader. An exception: the counterbalance mechanism is a torsion spring rather than weights. Four long-range hose loaders with a 114" reach, spaced 18" apart, will fully cover the API RP-1004 bottom loading envelope. The short-range loader with a 52" reach conforms to the API envelope, with three arms installed 24" apart.

### Benefits

- Easily adjustable torsion spring
- Makes loading simple
- Easy to handle and move
- Easily meets API envelope requirements

### Features

- Available in 2", 3" and 4"
- Available in carbon steel, stainless steel and aluminum
- Choice of flanged, threaded or all-welded construction

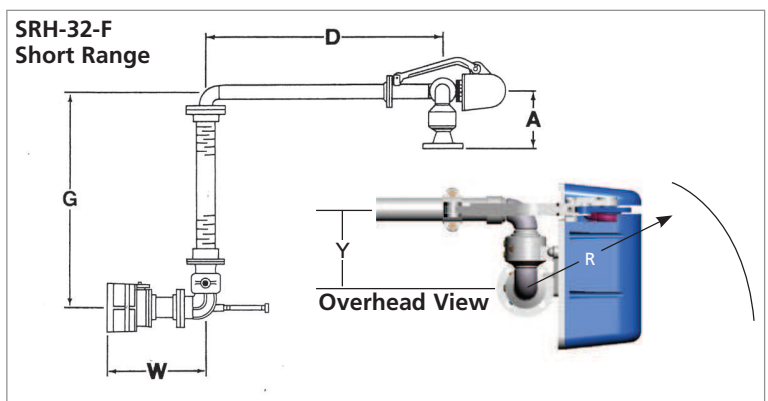
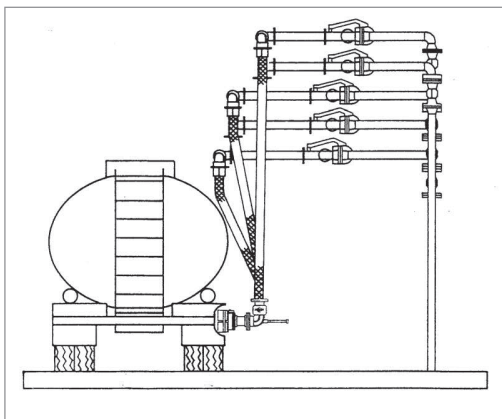

### Dimensions\*

Size		A		D		G		W		R		Y	
in.	mm	in.	mm	in.	mm	in.	mm	in.	mm	in.	mm	in.	mm
2"	51	8-5/8	219	52	1321	104	2642	15	381	17	432	8-1/8	206
3"	76	10-1/2	267	52	1321	104	2642	21	533	18-1/2	470	10-3/4	273
4"	102	11-3/4	298	52	1321	104	2642	21	533	20	508	12-3/4	324

\*Custom dimensions also available.

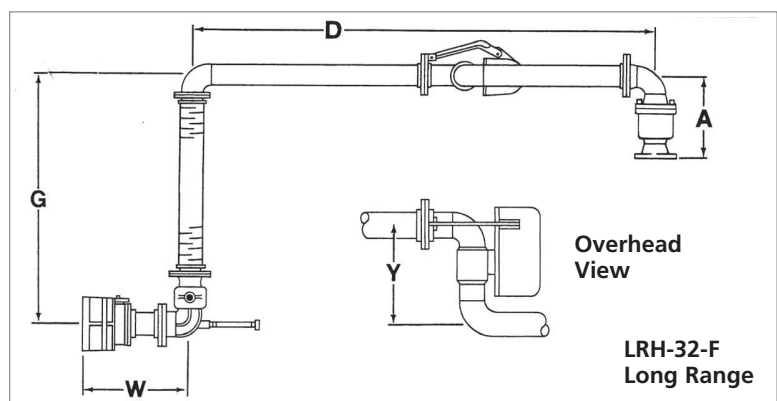

### Dimensions\*

Size		A		D		G		W		Y	
in.	mm	in.	mm	in.	mm	in.	mm	in.	mm	in.	mm
3"	76	10-1/2	267	114	2896	104	2642	21	533	20-1/2	521
4"	102	18-1/8	460	114	2896	104	2642	21	533	20-1/2	521

\*Custom dimensions also available.

**IMPORTANT:** OPW products should be used in compliance with applicable federal, state, provincial, and local laws and regulations. Product selection should be based on physical specifications and limitations and compatibility with the environment and materials to be handled. OPW MAKES NO WARRANTY OF FITNESS FOR A PARTICULAR USE. All illustrations and specifications in this literature are based on the latest product information available at the time of publication. OPW reserves the right to make changes at any time in prices, materials, specifications and models and to discontinue models without notice or obligation.

## 1004D3 and 1004D4 Bottom Loading Couplers

### The Safer, Cleaner, Faster Way To Load Your Transports

The OPW Engineered Systems' 1004D3 and 1004D4s are the standard in "drip-less" bottom-loading couplers and proven performers at major oil terminals worldwide. The 1004D3 and 1004D4 mate with all 4" bottom-loading adaptors built in accordance with API RP-1004 requirements to significantly reduce liquid loss at disconnect in gasoline applications.

The 1004D4 is the next generation in API Bottom Loading Couplers from OPW. By combining ease of maintenance with a unique spring-loaded sleeve design, the D4 provides the ultimate coupler experience.



1004D3 (Large Handles)



1004D4



1005E3 (Small Handles)

### Benefits

- Mates with all API RP-1004 4" bottom-loading adaptors
- Simple & easy maintenance – all pins have been eliminated to provide quick access to all critical components
- 5-Cam design ensures easy alignment and tight connection
- Dual interlocks ensures that coupler cannot be opened unless properly connected
- No special tools required – only 17mm and 32mm socket required to completely disassemble
- Mates with all API RP-1004 4" bottom-loading adaptors

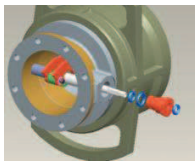

Quick and Easy Disassembly

### Seal Replacement Kits

The 1004D3 and D4 SRK Seal Replacement Kits include everything needed to replace all seals in the D3 and D4 API Bottom Loading Coupler. Seal replacement kits are always recommended as spare parts.

Seal Material	Model	Kit Part #
Buna-N	1004D3/1005E3	1004D3SRK - 0401
	1004D4	1004D4SRK - 0401
Fluorocarbon	1004D3/1005E3	1004D3SRK - 0402
	1004D4	1004D4SRK - 0402
EPDM	1004D3/1005E3	1004D3SRK - 0404
	1004D4	1004D4SRK - 0404

### Selection Guide

1 0 0 4 D 3	-	0 4	0 2
Style		Size	Seal
1004D3 (Large Handles)		4" Only	01 = Buna-N
1005E3 (Small Handles)			02 = Fluorocarbon
1004D4			04 = EPDM

### Design Parameters

Max Design Pressure	125 psi (g), 8.6 bar (g)
Max Allowable Working Pressure*	75 psi (g), 5 bar (g)
Max Flow Rate:	600 GPM, 135 M3/h
Temperature Range:	<ul style="list-style-type: none"> <li>• Fluorocarbon -20F to 400F (-29C to 204C)</li> <li>• Buna-N -20F to 250F (-29C to 121C)</li> <li>• EPDM -50F to 225F (-46C to 107C)</li> </ul>
Weight:	21 lbs (9.5 kg)
Pressure Drop: (At Max Flow Rate)	2-5 psi (g), .24 bar (g)*

\*Unit tested to 300 psi in closed position to withstand excessive thermal expansion pressures. Reference API standard RP-1004 for additional information.



- 1004DRN Drain Adaptor**
- Allows operator to easily, safely drain loading arm
  - Fits any API Bottom Loading Coupler



- 1004PA Parking Adaptor**
- Use to neatly store and secure loading arms while not in use
  - Can be provided with standpost and/or proximity switch



## Top Loading Overview

Top loading railcars and trucks continue to provide an efficient and cost-effective method to load and unload in many situations.

A loading system should have sufficient horizontal range to reach the farthest compartment without re-spotting the vehicle. Sufficient vertical movement and drop-pipe lengths for servicing vehicles of varying heights are also necessary. A properly designed top-loading system can achieve this requirement. Top loading can also be used for tight-fill and vapor-recovery applications when used with specially designed and engineered components, such as vapor plates, tapered hatch plugs and inflatable hatch seals.

The 7300 IHS Inflatable Hatch Seal is a device for sealing different hatch openings on tank trucks and railcars to prevent the release of vapors into the atmosphere.

Special top loading designs can be supplied with a wide range of valves, fittings and instrumentation equipment.

**OPW Engineered Systems** has a long, established reputation in the petroleum, chemical and food industries for providing effective loading and unloading systems to handle liquids safely and efficiently. OPW Engineered Systems works closely with you to design the best system for your application.

**IMPORTANT:** OPW products should be used in compliance with applicable federal, state, provincial, and local laws and regulations. Product selection should be based on physical specifications and limitations and compatibility with the environment and materials to be handled. OPW MAKES NO WARRANTY OF FITNESS FOR A PARTICULAR USE. All illustrations and specifications in this literature are based on the latest product information available at the time of publication. OPW reserves the right to make changes at any time in prices, materials, specifications and models and to discontinue models without notice or obligation.



## Single Arm Fixed Reach

### E-32-F, J-32-F

Primarily used to load and unload railcars through open domes in installations where the cars can be spotted accurately. The single arm configuration also can be used for tank-truck applications. Some allowance for mis-spotting is possible with the single arm and increases as the diameter of the hatch opening increases.

This simple arm incorporates only three swivel planes of rotation and is designed for use in top loading installations where the vehicle is located at a fixed distance from the riser pipe. The two swivel planes at the inlet permit both up-and-down and side-to-side movement of the assembly. The third swivel plane allows the drop pipe to remain vertical.

Valves can be located inboard or outboard to facilitate loading. With a valve located outboard, drippage of viscous products after loading can be minimized.

The single-arm loader is adaptable to tight-fill or closed-system loading when equipped with additional swivel planes of rotation and/or drop hose, along with required outboard coupling, union or fitting.

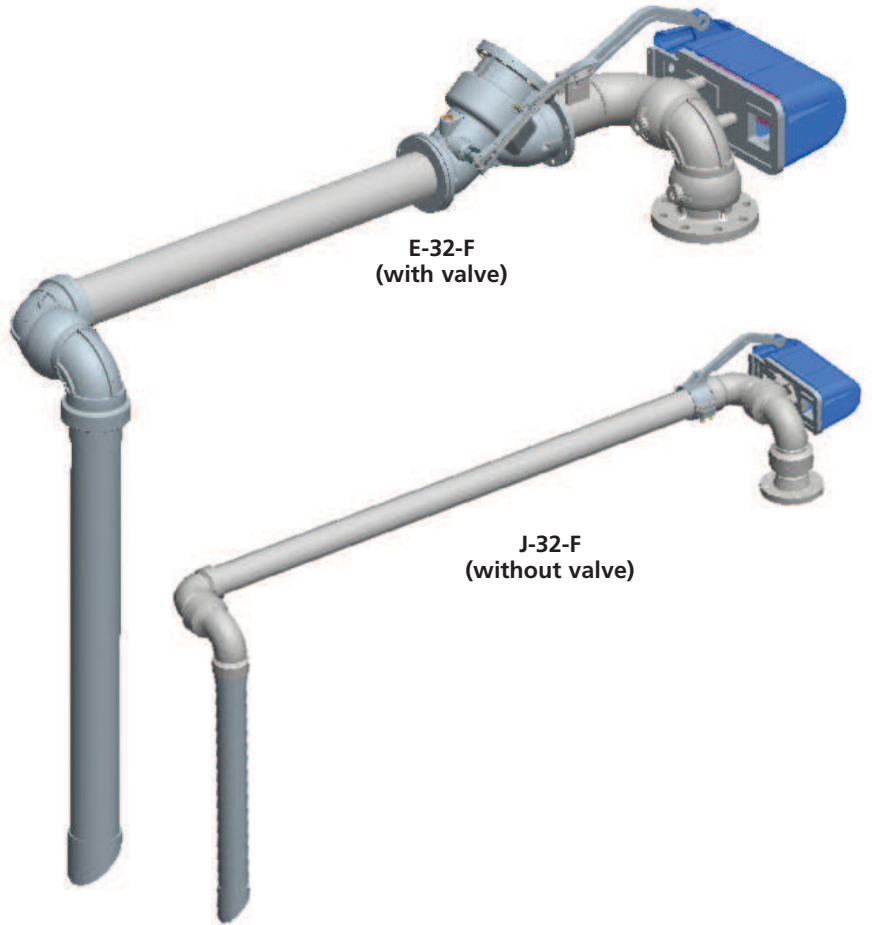

### Benefits

- Adaptable to tight-fill or closed-system loading when equipped with additional swivel planes of rotation and/or drop hose, along with required outboard coupling, union or fitting
- Rail or truck applications
- Smooth, easy operation

### Features

- Available in 2", 3" and 4"
- Available in carbon steel, stainless steel, aluminum and special alloys
- Choice of flanged, threaded or all-welded construction

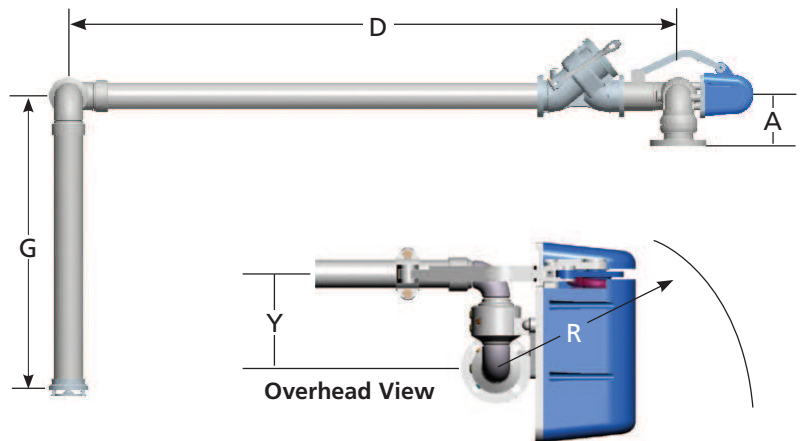

### Dimensions\*

Size		A		D		G		R		Y	
in.	mm	in.	mm	in.	mm	in.	mm	in.	mm	in.	mm
2"	51	8-5/8	219	120	3048	48	1219	17	432	8-1/8	206
3"	76	10-1/2	267	120	3048	48	1219	18-1/2	470	10-3/4	273
4"	102	11-3/4	298	120	3048	48	1219	20	508	12-3/4	324

\*Custom dimensions also available.

## Scissor Type Arm

### C-32-F, H-32-F

Commonly used to handle high flow rates and withstand rough usage in tank-truck loading applications, the scissor arm also is an excellent choice for railcar-loading installations where cars are frequently mis-spotted.

This versatile arm is designed specifically for top-loading installations where a variable operating range is required. The secondary arm rotates 360 degrees in the horizontal plane, providing a spotting allowance of up to twice its length.

**Note:** The scissor-arm configuration is not recommended in 6" size in all steel or stainless steel due to the difficulties an operator would have handling the heavy outboard components.

### Benefits

- Ideal for applications where spotting the vehicle is variable
- Adaptable to tight-fill or closed-system loading when equipped with additional swivel planes of rotation and/or drop hose, along with required outboard coupling, union or fitting

### Features

- Available in 2", 3" and 4"
- Available in carbon steel, stainless steel and aluminum
- Choice of flanged, threaded or all-welded construction

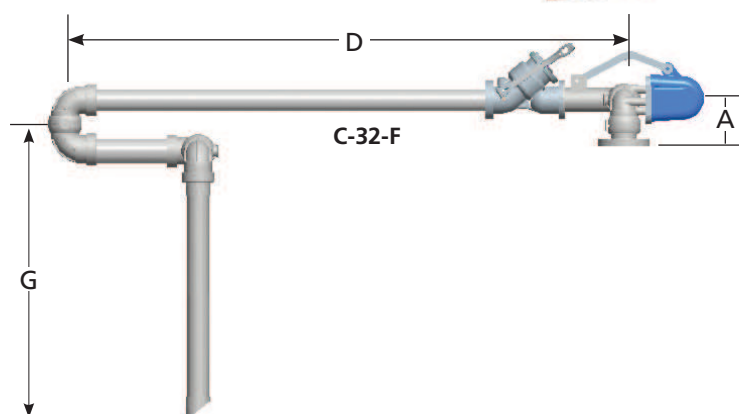
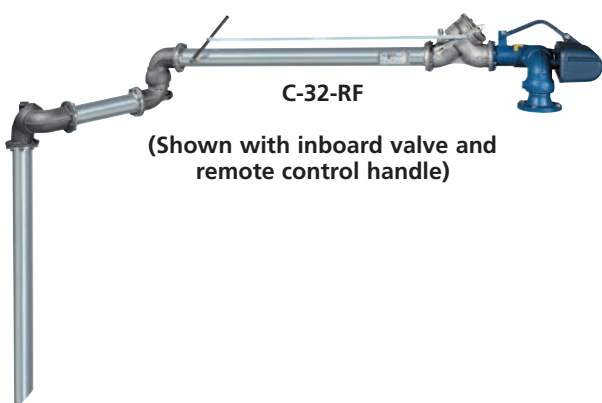
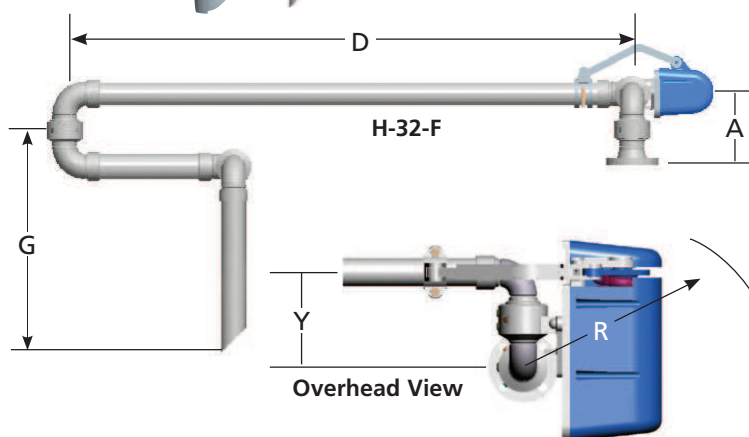
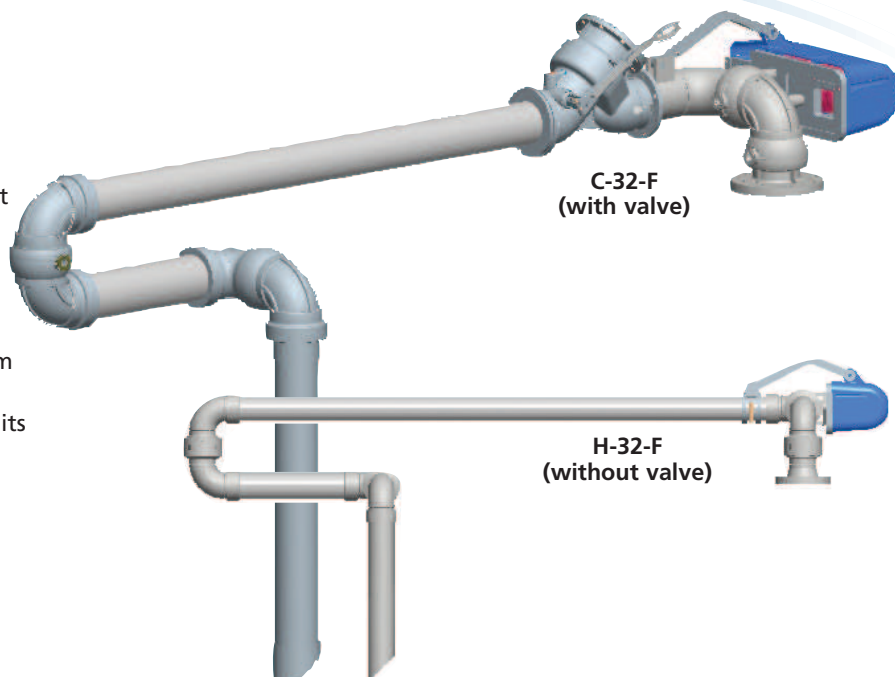

### Dimensions\*

Size	A		D		G		K		M		R		Y		
in. mm	in.	mm	in.	mm	in.	mm	in.	mm	in.	mm	in.	mm	in.	mm	
2"	51	8-5/8	216	84	2134	48	1219	8-1/8	206	24	610	17	432	8-1/8	206
3"	76	10-1/2	267	84	2134	48	1219	10-3/4	273	24	610	18-1/2	470	10-3/4	273
4"	102	11-3/4	298	84	2134	48	1219	12-3/4	324	24	610	20	508	12-3/4	324

\*Custom dimensions also available.

**IMPORTANT:** OPW products should be used in compliance with applicable federal, state, provincial, and local laws and regulations. Product selection should be based on physical specifications and limitations and compatibility with the environment and materials to be handled. OPW MAKES NO WARRANTY OF FITNESS FOR A PARTICULAR USE. All illustrations and specifications in this literature are based on the latest product information available at the time of publication. OPW reserves the right to make changes at any time in prices, materials, specifications and models and to discontinue models without notice or obligation.

## Supported Boom Arm

### B-32-F

This style arm provides dependable, low-maintenance service in high-usage installations. Due to the boom-mounted design, no heavy loads are placed on the swivel components to help minimize wear. In simplest terms, the supported boom arm loader consists of a single-arm loader mounted on a swiveling boom that is attached to a permanent structure, with either a pillow block or flange bearing for added strength and support. This configuration provides maximum flexibility for mis-spotting and longer reach from the loading rack to the railcar or tank truck. Both the boom and the arm can be folded back against the rack for convenient, compact storage away from traffic flow.

A variety of boom designs and configurations are available to meet the needs of virtually any installation. Used for tank truck and railcar open-dome loading, supported boom arms can be modified for closed-system loading and unloading.

Optional valves – such as dry disconnect, ball, butterfly or loading – can be used because of the boom support.

### Benefits

- Long reach
- Design flexibility means it can be used for any application
- Folded back on itself, it can be stored easily
- Optional valve and remote

### Features

- Available in 2", 3" and 4"
- Available in carbon steel, stainless steel, aluminum and specialty alloys
- Choice of flanged, threaded or all-welded construction

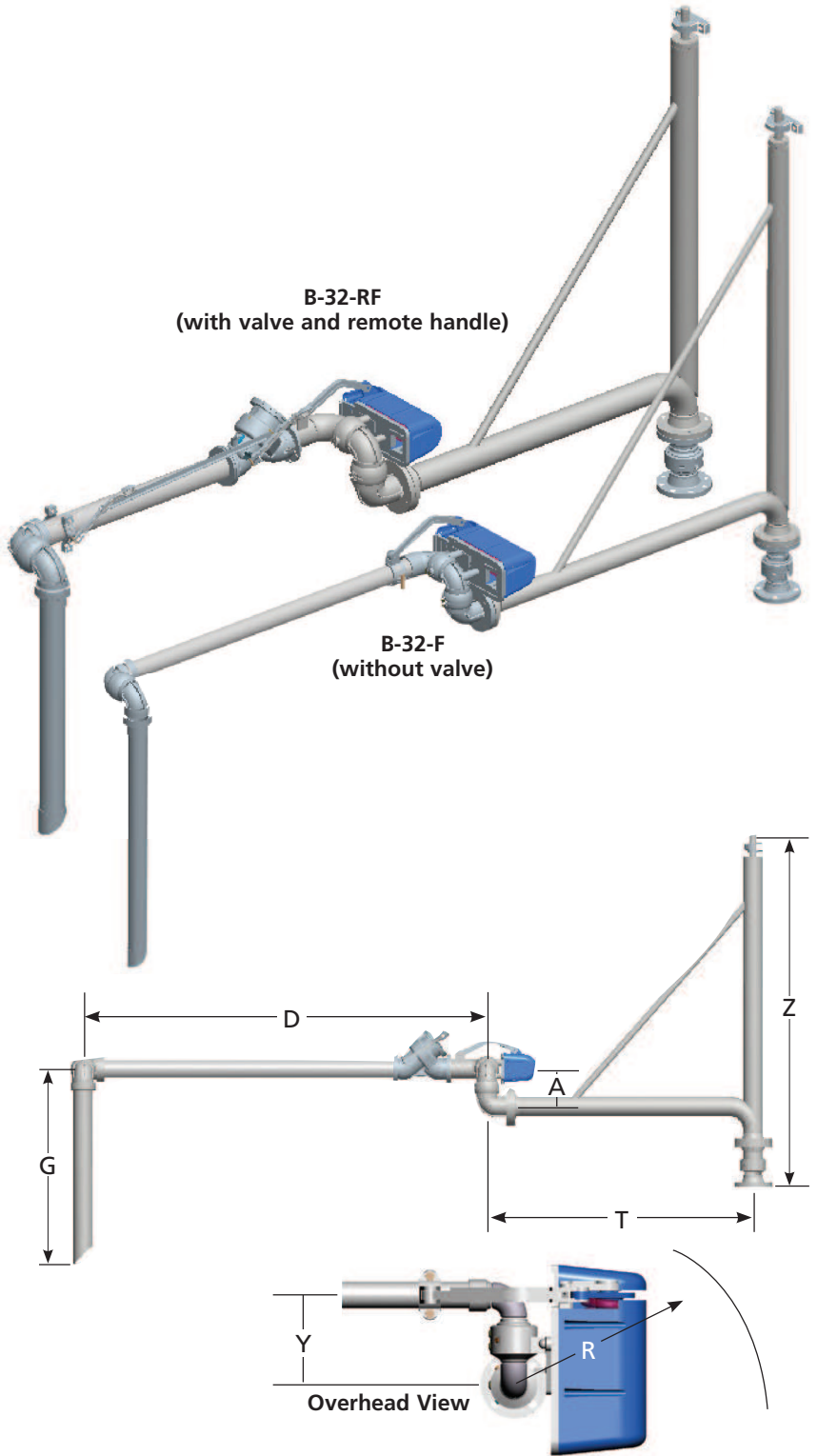

### Dimensions\*

Size	A		D		G		T		Z		R		Y		
	in.	mm	in.	mm	in.	mm	in.	mm	in.	mm	in.	mm	in.	mm	
2"	51	14-1/4	362	78	1981	48	1219	78	1981	84	2134	17	432	8-1/8	206
3"	76	17-3/4	451	78	1981	48	1219	78	1981	84	2134	18-1/2	470	10-3/4	273
4"	102	20-3/4	527	78	1981	48	1219	78	1981	84	2134	20	508	12-3/4	324

\*Custom dimensions also available.



## Unsupported Boom Arm GT-32-F

The unsupported boom arm is an excellent alternative for variable reach applications, especially in larger sizes where the outboard components are relatively heavy. It can be modified for closed-system loading and unloading, and is available in various design configurations to meet the needs of virtually any installation.

This popular-style loader is designed for those installations where it is undesirable or impractical to mount a supported boom arm. For example, many railcar sites have no support columns or overhead structures to which a supported boom can be attached.

The unsupported boom arm offers the same advantages as the supported boom arm, but maximum reach is somewhat less. It provides good flexibility for mis-spotting, and can be folded back against the rack for convenient, compact storage. When necessary, increasing the size of the base joint, or using a heavy-duty split flange swivel at the inlet, can extend total reach.

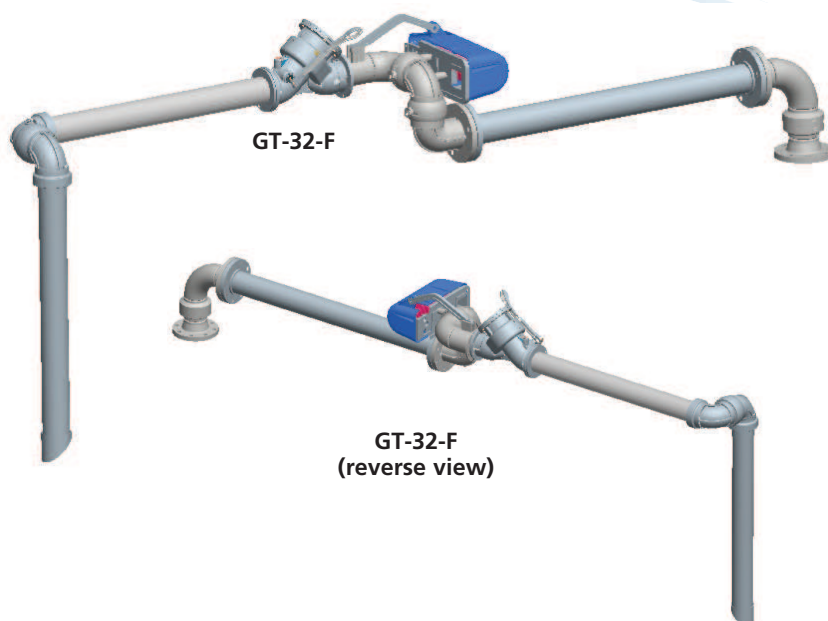

### Benefits

- Optional valving allows liquid to be held in the line
- Long reach compensates for mis-spotting
- Compact storage

### Features

- Available in 2", 3" and 4"
- Available in carbon steel, stainless steel, aluminum and specialty alloys
- Choice of flanged, threaded or all-welded construction

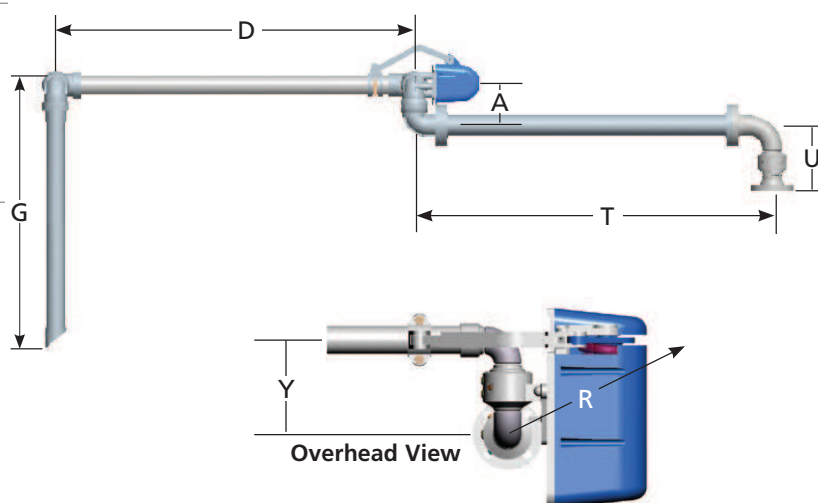

### Dimensions\*

Size		A		D		G		T		U		R		Y	
in.	mm	in.	mm	in.	mm	in.	mm	in.	mm	in.	mm	in.	mm	in.	mm
2"	51	8-1/8	206	78	1981	48	1219	48	1219	8-5/8	219	17	432	8-1/8	206
3"	76	10-3/4	273	78	1981	48	1219	48	1219	10-1/2	267	18-1/2	470	10-3/4	273
4"	102	12-3/4	324	78	1981	48	1219	48	1219	11-3/4	298	20	508	12-3/4	324

\*Custom dimensions also available.

**IMPORTANT:** OPW products should be used in compliance with applicable federal, state, provincial, and local laws and regulations. Product selection should be based on physical specifications and limitations and compatibility with the environment and materials to be handled. OPW MAKES NO WARRANTY OF FITNESS FOR A PARTICULAR USE. All illustrations and specifications in this literature are based on the latest product information available at the time of publication. OPW reserves the right to make changes at any time in prices, materials, specifications and models and to discontinue models without notice or obligation.

## Slide Sleeve Arm

### A-32-F

The slide sleeve type of arm incorporates a slide-sleeve assembly that telescopes in and out to adjust for variations in the distance from the loading rack to the hauling vehicle. It is used primarily in small bulk plants and terminals for top loading gasoline, fuel oil, or other petroleum products. This durable, dependable and cost-effective loading arm is time-tested as a practical method of locating the drop tube accurately and easily.

The slide sleeve is a medium-duty unit designed for flow rates up to 15 ft/sec (4.5 m/sec). Higher flow rates may tend to push the inner tube out beyond the loading point.

### Benefits

- Good for applications where the vehicle type varies
- Telescoping primary arm
- Deadman-type loading valve

### Features

- Typically supplied with female threaded inlet connections in 2" size (A-32), with 150 lb. ASME flanged inlet in 3" and 4" sizes (A-32-F)
- Both torsion spring-balanced and counterweighted slide-sleeve arms are available
- Available in 2", 3" and 4" sizes

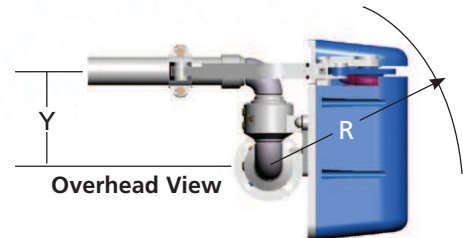
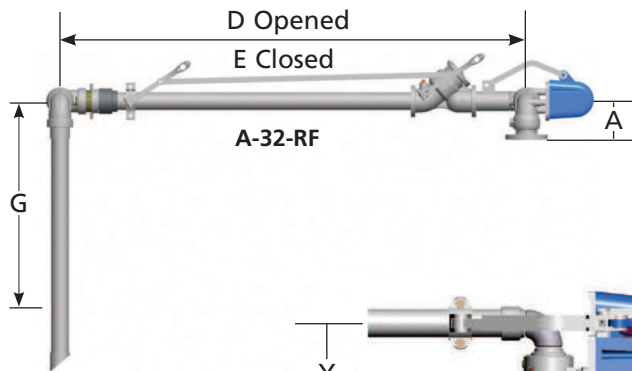
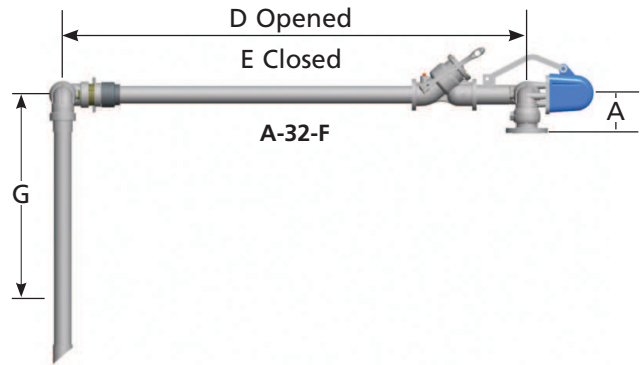
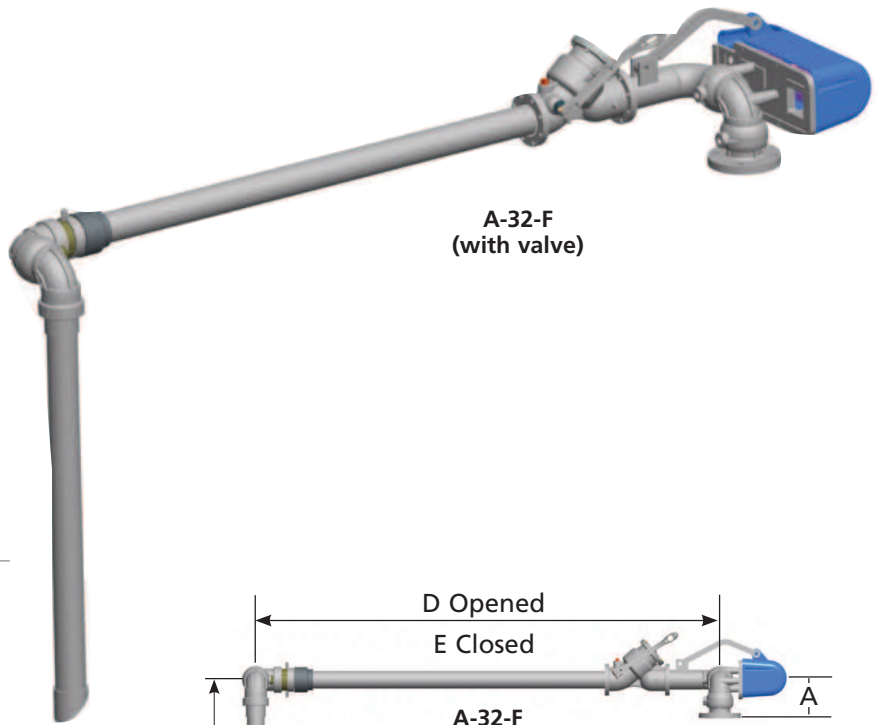

### Dimensions\*

Size	A		D		E		G		R		Y		
	in.	mm	in.	mm	in.	mm	in.	mm	in.	mm	in.	mm	
2"	51	5-5/8	143	126	3200	78	1981	48	1219	15-1/4	387	6-1/8	156
3"	76	6-7/8	175	131	3327	83	2108	48	1219	16	406	7-5/8	194
4"	102	8-1/8	206	135	3429	87	2210	48	1219	17-3/4	451	9-1/4	235

\*Custom dimensions also available.



## Top Loading Vapor Recovery Overview

The challenge of designing and manufacturing a vapor-recovery loading arm depends greatly on the information provided by the customer. OPW Engineered Systems has many tools in their arsenal to recover vapors.

Material compatibility and functional components in the system make up a good portion of the design considerations. Volume of vapors, sensing equipment location and weights are some of the other considerations.

Custom design and production capabilities give OPW Engineered Systems the versatility to respond to all your needs, from the simple to the most complex. And since OPW products are used by a broad spectrum of industries, including petrochemical, petroleum, refining, distilling, brewing, pharmaceutical, paint, and waste treatment, OPW is just as adept at designing and producing a high-volume, aggressive chemical-loading system creating a more modest drum-filling system.

OPW Engineered Systems combines state-of-the-art CAD (Computer Aided Design) systems with substantial knowledge and experience to optimize your vapor-recovery loading or unloading system.

Manufacturing and testing procedures meet or exceed industry standards, and all loading-arm assemblies are rigorously tested to ensure high quality. CNC equipment machines all critical dimensions within precise tolerances to ensure that each product meets rigid engineering specifications. As with every other part of OPW products, welding is an important quality factor. OPW Engineered Systems' welders are certified to ASME Boiler and Pressure Vessel Code, Section IX.

Additional testing, including radiography and material certifications, can be provided to meet your specific requirements. Special exterior surface preparation and painting are also available.

**IMPORTANT:** OPW products should be used in compliance with applicable federal, state, provincial, and local laws and regulations. Product selection should be based on physical specifications and limitations and compatibility with the environment and materials to be handled. OPW MAKES NO WARRANTY OF FITNESS FOR A PARTICULAR USE. All illustrations and specifications in this literature are based on the latest product information available at the time of publication. OPW reserves the right to make changes at any time in prices, materials, specifications and models and to discontinue models without notice or obligation.



## Top Loading Vapor Recovery Systems

OPW Engineered Systems offers the world's most complete line of top-loading vapor-recovery solutions. From its revolutionary dual-line Drylok™ technology system to its piggyback-style, dual arm, Siamese-style and inflatable vapor hatch solutions...OPW has you covered.



### Dual Line, Quick Connect Drylok™ Vapor Recovery Technology

OPW Engineered Systems' Dual Line Quick Connect Drylok™ Vapor Recovery Technology is an innovative closed-loop top-loading vapor-recovery system designed to enhance environmental protection through zero emissions while improving worker safety and productivity.

This system consists of two flow passage lines – one to convey the product, the other to recover and transfer the product vapors. Separate product and vapor arms can be installed at the loading rack, but systems that incorporate the product and vapor lines into a single system are preferred because both connections can be moved out to the transporter, simultaneously and conveniently.

#### The Dual Line Drylok™ Vapor Recovery System

Utilizes OPW Engineered Systems' Drylok™ Couplers at the termination point of the loading hose or arm. OPW Drylok™ Vapor Recovery Systems provide major benefits, including:

- **Reduced Emissions:** As the driest disconnect in the industry, the Drylok™ eliminates threaded connections that allow fugitive emissions. The Drylok™ meets emission requirements set by EPA, OSHA and TCEQ.
- **Time Savings:** Using the Drylok™ coupler/adaptor system, the average time to connect the loading arm to the railcar valves is reduced significantly – from 35-40 minutes down to 35-40 seconds.
- **Improved Health Benefits:** Workers just turn a lever to connect – no need for cheater bars, pipe wrenches, or hammers. No busted knuckles, heavy lifting or bending over for long periods of time.
- **Increased Railcar Safety:** The Drylok™ product is tamper-resistant, reducing the risk of sabotage, theft, and contamination. Only when the Drylok™ coupler and adaptor are mated is access enabled to the system.



Drylok™ Vapor Recovery Systems by OPW provide the safest and most efficient solutions available for the transfer of hazardous liquids and recovery of potentially hazardous vapors.

OPW Engineered Systems offers two basic top-loading vapor-recovery designs that can utilize the Drylok™ system over a wide variety of applications. The basic designs include:

### Piggyback Style Arm

This simple design is highly functional. It has a vapor line welded to the product arm. The versatile arm also can serve as an unloader by using the “vapor” line to pressurize a railcar or tank truck equipped with a permanent deep pipe.

### Dual Arm / Siamese Configuration

The most widely used vapor-recovery assembly style, this system features separate arms for product and vapor that are joined together at the inner boom structure. One of the more popular variations of this design also has the two counterbalance swivels and the outer arms joined together in a side-by-side arrangement to minimize the overall vertical dimension of the outboard assembly. On most dual-arm designs, the product line feeds from beneath and the vapor line from overhead.

When loading tank trucks and railcars equipped with permanent product and vapor connections, the end fittings on the loading arm are typically quick-disconnect couplings, unions, or flanges. The Drylok™ coupler system can be outfitted for use on dual-arm and Siamese configurations.

### Special Requirements

OPW Engineered Systems vapor-recovery loading and unloading solutions can be steam jacketed or traced, equipped with automatic shut-off controls, or outfitted with



whatever additional equipment may be required for your particular application. Please contact OPW at 1-513-696-1500 with special requirements.

### Open Dome Loading

OPW Engineered Systems offers a wide variety of vapor-recovery components for applications where loading takes place through an open dome. These include cover plates, tapered hatch plugs/cones and the OPW Inflatable Hatch Seal.

OPW Engineered Systems' vapor-recovery assemblies are available in 2", 3", 4" and 6". They also are available in steel, stainless steel, aluminum and specialty alloys.

Please consult the factory with your specifications and OPW Engineered Systems will design a vapor-recovery loading system to meet your needs.

## Hatch Cover Vapor Plates

Hatch cover vapor plates are used to retain and recover harmful vapors and avoid excessive splashing (especially on tank wash arms). They also are used to prevent dirt, moisture, insects and foreign objects from entering the tank.

### Features

- Can be configured many ways, including dry-break couplings
- Made of steel, stainless steel or aluminum
- Can be added to the arm when needed
- Long-lasting, durable construction



Hatch Cover Vapor Plates



Tapered Hatch Seal

**IMPORTANT:** OPW products should be used in compliance with applicable federal, state, provincial, and local laws and regulations. Product selection should be based on physical specifications and limitations and compatibility with the environment and materials to be handled. OPW MAKES NO WARRANTY OF FITNESS FOR A PARTICULAR USE. All illustrations and specifications in this literature are based on the latest product information available at the time of publication. OPW reserves the right to make changes at any time in prices, materials, specifications and models and to discontinue models without notice or obligation.



▶ This M-32-F spring-balanced loader (right) is ideal for bottom loading petroleum-based products, including gasoline, diesel, biodiesel and ethanol.



◀ This G-32-F (left) is attached to a riser located at ground level. It offers an easy way to bottom unload a railcar. While not in use, you can see how it is easily "parked" outside the railroad envelope. Further down the tracks, you can see a hose attached to a riser, inside the envelope and perilously close to the rail.

▶ The photo to the right shows a bypass loading arm. In this application, the loading arm is not carrying product but is carrying the load of the pipes above it. This application is typical of a situation where the customer wanted to use components that were compatible with the liquid, plus needed the arm to act as a support, holding the load while making it easy to manipulate and control loading.



◀ The photo to the left shows how loading arms can be made to crossover each other to facilitate loading of various compartments in a tanker truck. Note the canopy. Its height limited the vertical travel of the loading arms. Design considerations like this are very important. Your OPW sales representative will be glad to make an on-site evaluation of your loading area.





## Custom Applications Overview

**OPW Engineered Systems** takes pride in its ability to custom-design and manufacture loading arms for specialized applications. With extensive experience, it's likely OPW engineers already have solved most situations you may encounter. Note there are many varying factors that impact fluid dynamics, and so there are no hard-and-fast rules for determining exactly what type of loader must be used in each installation. Personal preference, operating experience and methods, safety requirements and local customs all warrant consideration.

***In order to design a loading arm for your application, consider the following:***

- Liquid product to be handled (Temperature and Pressure)
- Type of tank or container to be used
- Flow rate

- Adequate capacity without excessive pressure drop
- Physical facility dimensions and limitations
- Adequate horizontal and vertical range
- Ease of operation
- Ease of maintenance
- Special requirements
- Cost

Within the limits of design and functionality, nothing is "too special." As industries have become more aware and responsive to environmental issues, loading systems offer a sound solution to the extremely critical process of transferring hazardous products from bulk storage tanks to rail or road vehicles.

All units can be factory pre-assembled and tested, and all **OPW Engineered Systems'** products are built to the highest quality standards.

**IMPORTANT:** OPW products should be used in compliance with applicable federal, state, provincial, and local laws and regulations. Product selection should be based on physical specifications and limitations and compatibility with the environment and materials to be handled. OPW MAKES NO WARRANTY OF FITNESS FOR A PARTICULAR USE. All illustrations and specifications in this literature are based on the latest product information available at the time of publication. OPW reserves the right to make changes at any time in prices, materials, specifications and models and to discontinue models without notice or obligation.



## Steam Jacketed Loading Arms

Endura Dual Split Flanged Loading Arms can be fully or partially jacketed for efficient handling of asphalt, molten sulfur, waxes, resins and other products that are highly viscous or tend to solidify at ambient temperatures.

- Top-and bottom-loading arm designs – fully or partially jacketed
- Custom designed based on product, temperature, reach and flexibility of your application
- Rugged construction in steel or stainless steel
- Available in 2", 3", 4" and 6" sizes
- Dual split flange design minimizes potential cold spots



## Automatic Shutdown

Any top-loading arm can be equipped with an automatic shut-off feature to help prevent spillage and overfills.

- Electrical and pneumatic systems available
- Adjustable to stop flow at predetermined level
- Can be configured to activate valves or alarms

*The systems shown are some of the more popular configurations. Many others are available and can be tailored to meet your specific requirements.*



## Custom Insulation Packages

Whether your loading arms are fully or partially steam jacketed or simply require insulation, OPW can provide a custom insulation package designed specifically for your loading arms. Unlike field-applied insulation, these packages are completely removable and reusable, making them the ideal solution for loading arm use.

- **Removable & Reusable** – All components of the arm are jacketed independently and can be removed easily for routine servicing and maintenance. Field-applied insulation is typically very difficult to remove.
- **Safer** – Heated arms can pose a potential burn hazard to operators. OPW Insulation Packages ensure the loading arm is properly insulated to protect your personnel.
- **Superior Heat Retention** – Consisting of 2" thick, low-density fiberglass helps ensure outstanding heat retention.
- **Durable** – Outer jacketing of PTFE Impregnated Fiberglass Cloth ensures your jackets will hold up to the rugged environments to which loading arms are exposed.



### Construction Details

- **Inner Jacketing** – 17 oz./sq. yd. PTFE Impregnated Fiberglass Cloth
- **Outer Jacketing** – 17 oz./sq. yd. PTFE Impregnated Fiberglass Cloth
- **Insulation** – 2" THK, low-density Fiberglass
- **Thread** – PTFE-Coated Fiberglass Thread
- **Attachments** – PTFE Cloth Belts with stainless-steel double-D rings; drawstring flaps with Nomex Cord
- **I.D. Tags** – Stainless-steel embossed



**IMPORTANT:** OPW products should be used in compliance with applicable federal, state, provincial, and local laws and regulations. Product selection should be based on physical specifications and limitations and compatibility with the environment and materials to be handled. OPW MAKES NO WARRANTY OF FITNESS FOR A PARTICULAR USE. All illustrations and specifications in this literature are based on the latest product information available at the time of publication. OPW reserves the right to make changes at any time in prices, materials, specifications and models and to discontinue models without notice or obligation.



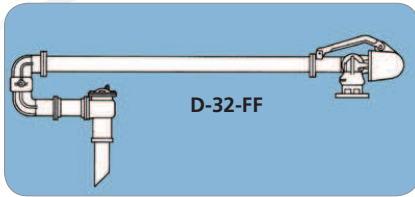

**D-32-FF Scissor Arm**  
with Valve Outboard  
for Viscous Products

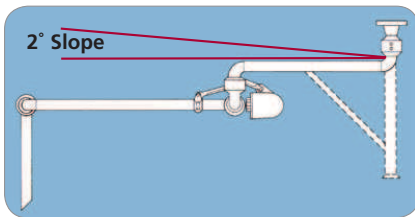

**Boom-Type Loader**  
with Self-Draining Configuration

(Note: The primary arm section is angled down for drainage)



**C-33-RF Scissor Arm**  
with Downfeed Loading

- Deadman loading valve with remote control operating lever and outlet deflector

**Remote Control Unit (1000-RC)**

The OPW 1000-RC remote control unit provides convenient control of the loading valve from the outboard end of the loading arm. The 1000-RC consists of an arm clamp, lever handle and connection rod. Available for all OPW Type A, B, C and E liquid loaders.

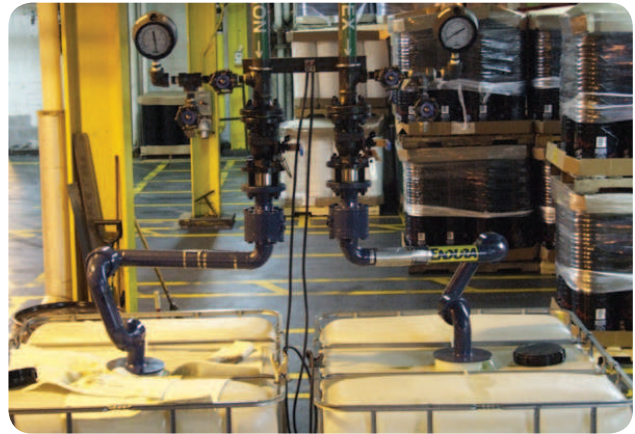

**Drum/Tote-Filling Arms**

- Makes it easy to load both open drums and those with small bung openings
- Designed to provide the range of flexibility needed for loading drums/totes at any orientation on pallet
- Easy operation ensures faster loading



**By-Pass Loading Arms**

OPW By-Pass Loading Arms are designed as a low-cost alternative to arms constructed of Hastelloy®, Alloy 20® and other specialty metals used to transfer hydrochloric acid and other corrosive chemicals.

This unique design offers:

- All the ease of operation and handling advantages of conventional spring-balance loaders
- Liquid bypass of steel swivel – no liquid passes through the base swivel
- Base swivel, in conjunction with torsion spring, serves as a support and carrying mechanism only
- Flow passage – consists of lined pipe, plastic pipe, and a hose suspended from the support arm
- Available in 2", 3" and 4" sizes in a variety of configurations

## Pneumatic Controlled Loaders

The OPW Engineered Systems' pneumatic-controlled loaders are designed specifically to help make operations simpler, safer and more efficient. Pneumatic-actuated loading systems utilize air to create leverage points that allow the loading arm to be moved and positioned effortlessly. And because they are designed for precision control, these loaders can be handled easily by one operator, without heavy pushing, pulling or lifting.



### Benefits

- Easy to operate/maneuver, air-controlled actuation eliminates strenuous pushing, pulling or lifting
- Long-range design to compensate for vehicle misplacement
- Easily stores away from vehicles
- Safely stores outside the envelope of clearance
- Available in both bottom and top-loader configurations

### Features

- Available in 2", 3", 4" and 6"
- Available in steel, stainless steel, aluminum and specialty alloys
- Choice of flanged, threaded or all-welded construction

**IMPORTANT:** OPW products should be used in compliance with applicable federal, state, provincial, and local laws and regulations. Product selection should be based on physical specifications and limitations and compatibility with the environment and materials to be handled. OPW MAKES NO WARRANTY OF FITNESS FOR A PARTICULAR USE. All illustrations and specifications in this literature are based on the latest product information available at the time of publication. OPW reserves the right to make changes at any time in prices, materials, specifications and models and to discontinue models without notice or obligation.



## Loading Rack Hose Covers

Hose covers are a natural option for all OPW bottom loading arms. These easy-to-install, zippered covers help drivers quickly identify the product being handled. This not only helps protect the equipment, but also helps avoid costly cross contamination of product.

- Prevent unsightly scuffs to costly tank logos
- Visually identify petroleum products
- Protect drivers from protruding wires
- Available in all API color codes
- Custom lengths and sizes available

### Construction Details

- **Inner Jacketing:** Sun-Resistant, Heavy-Duty Nylon
- **Outer jacketing:** Sun-Resistant, Heavy-Duty Nylon
- **Inner Core:** Foam
- **Thread:** PTFE-Coated Fiberglass Thread
- **Attachments:** Heavy-Duty Zipper



## Deflectors

To prevent static build-up, foaming, impingement on the bottom of the tank and to keep the drop pipe from rising, OPW Engineered Systems manufactures both T-style and cone-type deflectors. Available in 2" through 6" sizes, the standard product is made of aluminum. Other materials of construction are available to meet the needs of more corrosive chemicals.



**OPW-ES 363**  
Cast aluminum with female threads for 2" or 6" liquid loaders used on gravity discharge lines.

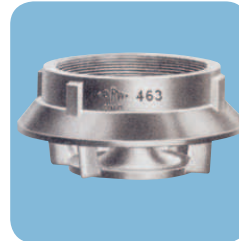

**OPW-ES 463**  
Cast aluminum with female threads for 3" or 4" liquid loaders. Vertical wing ribs prevent drop tube from rising when filling. Accelerates discharge and prevents roiling of product when used on pressure discharge line.



**OPW-ES 464**  
Cast aluminum tee with female threads. Especially designed for handling jet fuel. Prevents high-velocity impingement on bottom of tank to reduce possibility of ignition of jet fuel. Available in 3" and 4".

## Strainers

OPW strainers are used on suction lines during the unloading of tank cars to prevent scale and other foreign objects from being sucked into the line. This aluminum-cast product is designed with legs on the outlet to keep the inlet off the bottom of the tank. It has a 4-mesh galvanized-steel screen. The inlet is standard internal pipe threads. Available in 3" and 4" sizes.



**OPW-ES 341**



# Swivel Joints

## Endura™ 8000 Series Dual Split Flange "DSF"

- Best available swivel-joint technology
- Designed specifically for chemical/ industrial loading arm use

- Available in 2", 3" and 4" sizes; carbon steel and all stainless-steel versions in all styles
- 500-psi pressure rating

## Endura™ DSF Swivels

### Redundant Sealing

- Incorporates a main seal, back-up seal, static product seal and environmental seal
- If main product seal ever leaks due to normal wear, the back-up seal contains the fluid
- Any main seal leakage would be channeled to leak-detection port
- Environmental seal provides a third layer of protection

### Bearing Module

- Deep groove replaceable dual and single race ball-bearing technology
- Easy replacement or rebuild options
- Ball removal not required to access main seals
- Endura™ 8700-8900 series feature ALL stainless-steel construction

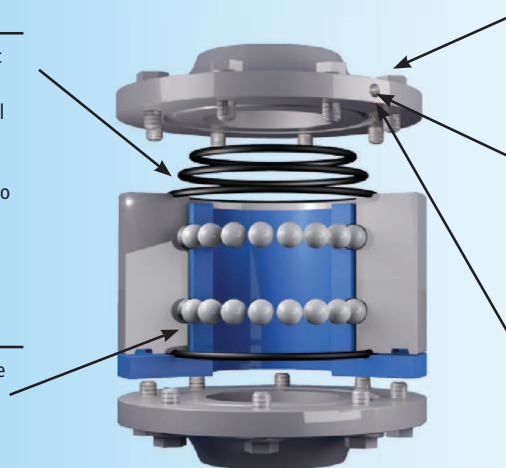

### Easy Maintenance

- Simply unbolt sealing flanges to access seals
- No ball bearings to remove

### Leak Detection Port

- In the event of main seal leakage, fluid would be channeled to leak-detection port
- Quick and easy way to monitor performance so that maintenance can be performed

### Purge Port

- For critical applications, an inert gas can be injected at leak-detection/purge port
- Inert gas pressure higher than product pressure to virtually eliminate risk of fugitive emission
- Recommended for your extreme applications!

# Swivel Joints

## 3000 Series Swivel Joints

- **Tight Seals**
  - O-Rings provide a tight seal without hindering swivel action
- **True Ball Bearing Race Alignment**
  - Body and tail sections are locked together by a double row of ball bearings
- **Protected Bearing Chamber**
  - Outer seal keeps out rain, dirt and other contaminants
- **Long-Life Bearings**
  - Ball bearings are hardened, precision-ground steel
  - Stainless-steel swivels have stainless-steel bearings
- **Easy Lubrication**
  - All OPW swivels pre-lubricated at the factory
- **No Field Adjustment Necessary**
  - Balls are held in place by factory-installed plugs (never need adjustment) to maintain bearing performance

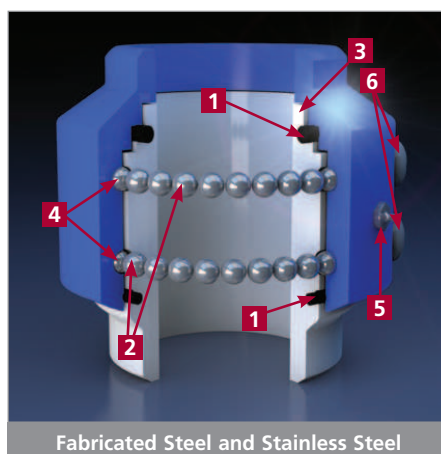

## OPW 880 LUBRICANT

- 100% synthetic
- Formulated to reduce friction and wear
- Will not melt, drip or carbonize
- Compatible with all seal materials
- Complies with FDA regulation 21 CFR 178.3570
- Requires only annual lubrication
- Temp range: -40°F to 750°F (-40°C to 400°C)

For more information on OPW's complete swivel line, refer to the OPW Engineered Systems Swivel Joints Catalog.

**IMPORTANT:** OPW products should be used in compliance with applicable federal, state, provincial, and local laws and regulations. Product selection should be based on physical specifications and limitations and compatibility with the environment and materials to be handled. OPW MAKES NO WARRANTY OF FITNESS FOR A PARTICULAR USE. All illustrations and specifications in this literature are based on the latest product information available at the time of publication. OPW reserves the right to make changes at any time in prices, materials, specifications and models and to discontinue models without notice or obligation.

## Counterbalance Units

- Easy, precise, one-nut adjustment
- No special tools required
- Eliminates labor-intensive steps associated with other counterbalance units
- Wide range of motion
- Stable balancing

- Fully adjustable upward/downward travel stops
- Available in right-handed or left-handed configurations
- Safe, robust design
- 5-year warranty

### 790 Series-EZ Adjust



### 890 Series Hi-Load Counterbalance



- Highest load capacity
- Ideal for longer-reach applications
- Easy, safe adjustment
- Stable balancing through entire range of motion

A full range of spring-balance adjustment with the turn of a wrench — **GUARANTEED!**

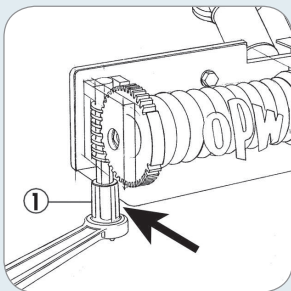

1. Place 5/8" socket wrench on worm gear hex drive (NOTE: Under high load conditions, it may be necessary to raise loading arm to 45° above horizontal).

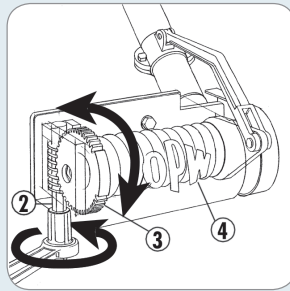

2. Turn worm gear hex drive which...  
3. Turns gear, which...  
4. Winds or unwinds spring.

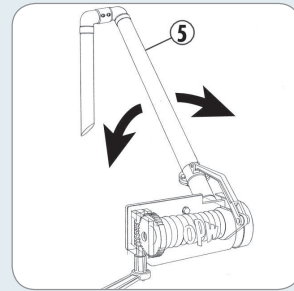

5. Winding action produces the necessary torque (lifting action) required to counterbalance the loading arm.

## Counterbalance Units

### Pneumatic Cylinders

- Ideal for heavy-load applications
- Eliminates strenuous pushing, pulling or lifting
- Can be designed to provide movement in single or multiple planes, up to and including fully robotic arm
- Plug & Play Control Package
  - Weather-proof enclosure
  - Includes air regulator, dryer and speed controls
  - Push-button pendant controller

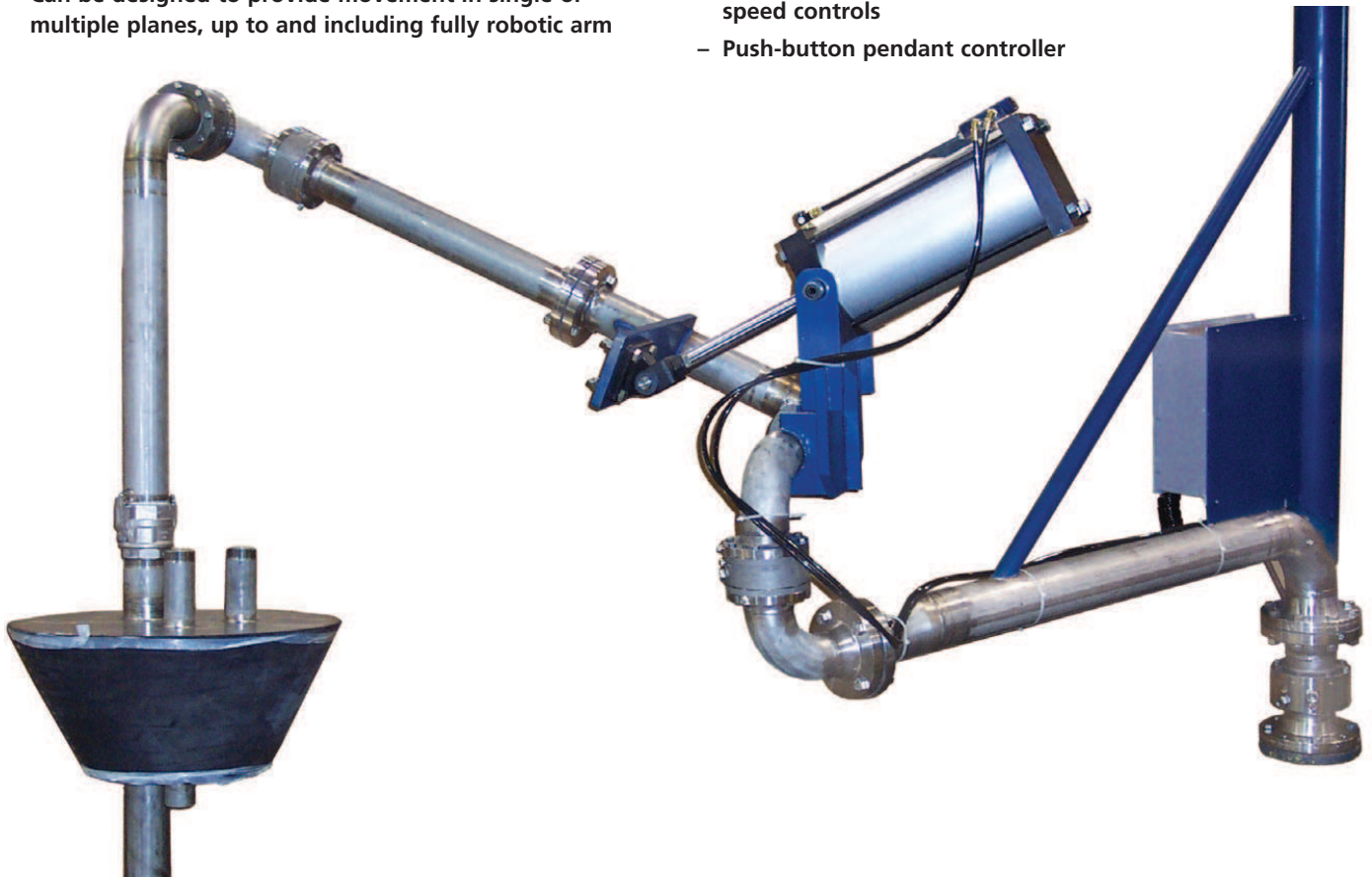

**IMPORTANT:** OPW products should be used in compliance with applicable federal, state, provincial, and local laws and regulations. Product selection should be based on physical specifications and limitations and compatibility with the environment and materials to be handled. OPW MAKES NO WARRANTY OF FITNESS FOR A PARTICULAR USE. All illustrations and specifications in this literature are based on the latest product information available at the time of publication. OPW reserves the right to make changes at any time in prices, materials, specifications and models and to discontinue models without notice or obligation.



## Safety Breakaway Devices

### NTS-PU Series (Pull-Away) Breakaway Coupling

#### Areas of application

The OPW Engineered Systems' NTS-PU Series Breakaway protects loading facilities, hoses and prevents spills at the same time. Separation occurs by a simple pulling force on the hose line. It finds its application in fluid and gas transfer. The OPW Engineered Systems' NTS-PU is axially built into hose lines (see example design at right).

#### Construction of the NTS-PU Series

The NTS-PU consists of two halves (Adaptor and In-line), each equipped with spring-loaded valves. A straight or angular pulling force on the hose triggers the separation. To protect the hose line from damage, the separation force of the NTS-PU can be individually adjusted.

#### Function

While coupled, the valves of the Emergency Release System NTS-PU are open. Upon a pre-determined pulling force, the separation occurs. Both valves close, thus preventing spills and protecting the loading station at the same time.

The NTS-PU allows for a spare-part-free, non-destructive separation – no shear pins involved and no destruction.

After depressurizing and emptying the hose, the NTS-PU can be reassembled easily, without tools or spare parts.



**Material:** Stainless Steel (316), Anodized Aluminum  
Others available upon request

**Seals:** Fluorocarbon, EPDM, Chemraz®

**Pressure Ratings:** 360 psi for all sizes (Alu 232 psi)

**Connections:** FNPT or Flange (TTMA/150/300 ANSI) 1", 2", 3", 4"

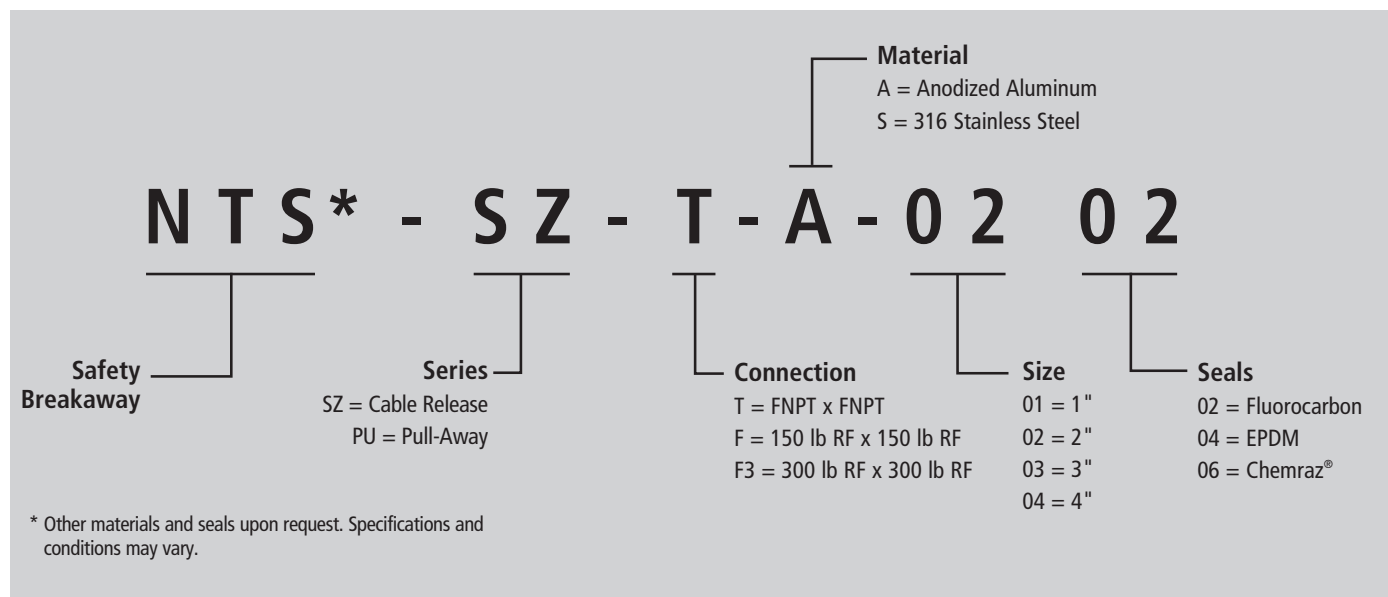

## Safety Breakaway Devices

### SZ Series (Cable Release) Breakaway Coupling

#### Areas of application

The SZ Series Emergency Breakaway Coupling with cable control is designed to protect against unintended pull-aways of tank trucks, railcars, barges or ships. Loading arms and hose lines, conveying gases or liquid media, can be either newly equipped or retrofitted with the SZ Series.

#### Structure

Two non-return valves prevent product loss in case of emergency separation. Both coupler halves are held together with segments and a slide ring. A cable pull triggers the separation by flipping the levers out of their locked position. The NTS® also is available with the proactive remote or hand separation.

#### Function

In a pull-off, the tensile force travels along the cable, leaving the hose or loading arm tension-free at all times. The levers are released, two non-return valves positively shut both ends, enabling the separation to occur. In contrast to most existing products, the SZ Series breakaways work independently from the working pressure and allow for a protective approach without the need to wait for an impact. With a proven track record of more than 25 years, the SZ Series Breakaway has earned an outstanding reputation of reliability in the industry.



Shown with optional proximity switch

#### Benefits

- Protection of loading-arm components
- Protection of loading facility
- Spill prevention
- Reconnectable

**Materials:** Stainless Steel (316)  
Others available upon request

**Seals:** EPDM, Fluorocarbon, Chemraz®

**Pressure Ratings:** 150 to 600 psi.

Available in 1", 2", 3", 4" and 6" (other sizes up to 12" available upon request)

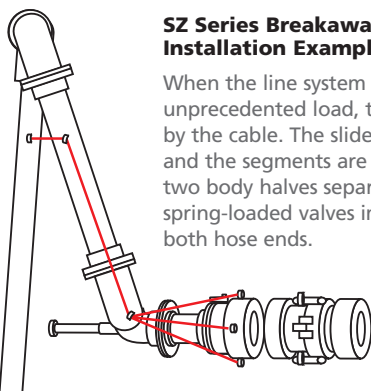

#### SZ Series Breakaway Coupling Installation Example

When the line system is subjected to an unprecedented load, the levers swing out by the cable. The slide ring is displaced and the segments are released. Then the two body halves separate and the two spring-loaded valves immediately shut both hose ends.

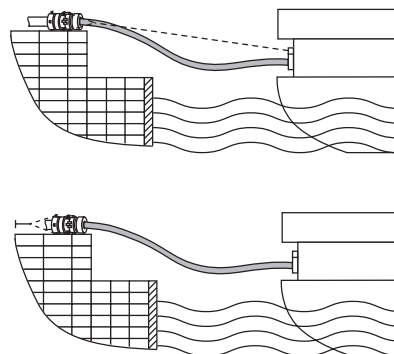

#### SZ Loading Arm Marine Installation Example

**Note:** The length of the SZ cable must be shorter than the maximum movement of the loading arm hose in order to trigger the separation.

**IMPORTANT:** OPW products should be used in compliance with applicable federal, state, provincial, and local laws and regulations. Product selection should be based on physical specifications and limitations and compatibility with the environment and materials to be handled. OPW MAKES NO WARRANTY OF FITNESS FOR A PARTICULAR USE. All illustrations and specifications in this literature are based on the latest product information available at the time of publication. OPW reserves the right to make changes at any time in prices, materials, specifications and models and to discontinue models without notice or obligation.

## Dry Disconnects

OPW Engineered Systems' dry-disconnect couplings prevent spillage from both routine and accidental disconnects. A dry disconnect consists of a built-in valve and a spring-loaded poppet in the mating adaptor that automatically closes when disconnected. OPW's line of dry disconnect products include Drylok™ and the economical Kamvalok®. Both Drylok™ and Kamvalok® are suitable for a wide range of hazardous transfer applications.

### Drylok™

Drylok™ is designed to transfer hazardous, corrosive, volatile liquids safely. An interlocking handle averts accidental spills by preventing uncoupling while the valve is open. And the unit's flat face minimizes fluid loss, further reducing "exposure to risk" during operation.



### Benefits

- **Driest disconnect in the industry** – less than 1-cc of fluid loss from a 3" unit.
- **Unprecedented safety** – meets or exceeds all of today's stringent emission and worker safety requirements set by EPA, OSHA and others. Drylok™ cannot be uncoupled while the valve is open.
- **High-pressure line applications** – rated at 300 psi in the open and flowing position.
- **Can be opened and closed against 150 psi maximum head pressure.**
- **Optimum flow rate** – unique design optimizes the flow rate in high-pressure or high-viscosity applications.

### Features

- Available in 1", 2" and 3" sizes
- Standard O-Ring seals for longevity and economy
- Adjustable packing nut with V-type material – provides a continuous compression, emission-free seal on handle shaft
- Available in 316 Stainless Steel, Alloy 20® or Hastelloy® C with NPT, BSP, ASME Flanged, BW and SW end connections
- AAR Approved and CRN Approved.

### Kamvalok®

OPW Kamvalok® Dry Disconnect Couplings, the industry standard, are used at liquid transfer points where product loss could occur. OPW Kamvaloks® provide a reliable solution to prevent spillage during connection or disconnection.



OPW Kamvalok® Dry Disconnect Couplings are used by a wide range of manufacturing applications including petroleum products, solvents, Ag-chemicals, vegetable oils, detergents and many acids and caustics.

### Benefits

- **Spill Protection** – helps to reduce the hazards involved in the connection/disconnection process of transferring materials.
- **Provides For Total Closed-Loop Loading Capabilities** – when used with the OPW 2173N Vapor Recovery Dry Disconnect Coupling protects people and property from dangerous and potentially costly exposure by keeping hazardous liquids and vapors in-line.
- **Dual Protection** – OPW Kamvaloks® provide automatic closure from both directions – the coupler and the adaptor.

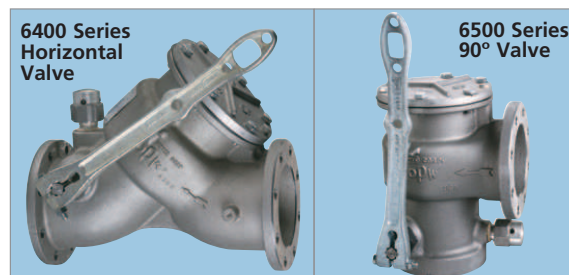

## Loading Valves

OPW Engineered Systems' Loading Valves are designed to shut off flow without causing damaging shock in the pipeline. Pipeline shock, or "hammer," causes problems with pipe joints and instruments in the line. Fast, shockless closing is assured by use of an adjustable needle valve and a dashpot. Air cannot be trapped in the valve, and as a result, the valve does not open after closure. This variable closure rate controls shock with minimum afterflow. Loading valves are available in several styles.



### Vacuum Breakers

OPW Engineered Systems' Vacuum Breakers for high-pressure applications permit quick, positive evacuation of the arm after the loading operation is complete. The 476SA model is available in aluminum with stainless-steel internal parts. The 489 model is stainless-steel for severe applications and tough liquids.

- Aluminum – Fluorocarbon
- SST – Metal Seats



## Rack Monitors

OPW Engineered Systems supplies a complete line of CIVACON™ brand rack monitors used in loading and unloading operations. The monitors can detect the type of sensor, the state of liquid in the tank, an overflow situation, and/or verify the grounding condition.

### 8580 Diagnostic Opti-Therm

- Automatically recognizes the type of overflow system (optic or thermistor signal technology)
- Diagnostic capabilities including ground verification, permissive status and compartment identification; mode of operation appears on LED screen
- The 8580 high-tech system limits the possibility of errors
- Can be used on systems that include up to twelve optic and eight thermistor sensors
- Separate output relays for overflow and ground verification result in superior flexibility and safety
- Easy-to-read, high-resolution 3" x 5" LED diagnostic display
- Monitors overflow status and sends shut-down signal to terminal-automation system



#### SPECIFICATIONS – 8580 DIAGNOSTIC OPTI-THERM

<b>Operating Temperature:</b> -40°F to 140°F (-40°C to 60°C) <b>Input Requirements:</b> 120 VAC 60 Hz, 15VA (Standard); 240 VAC available <b>Output Relay Contacts:</b> 240 VAC – 5A DPDT	<b>Response Time:</b> 0.5 seconds maximum, dry to wet transition <b>Electrical Connections:</b> Internal Terminal Strips <b>Enclosure:</b> NEMA 4 explosion-proof, Class 1, Div. 1, Group D	<b>Housing Material:</b> Aluminum <b>Approximate Weight:</b> Model 8580 – 43 lbs. <b>Approvals:</b> UL, CUL (Canada); CENELEC (Europe)
---	---	--

### 8460 Opti-Therm

The 8460 Opti-Therm Overflow Detection System recognizes the signal technology, optic or thermistor type on the transport, verifies grounding, and communicates with the terminal automation system (T.A.S.). The system enables maximum flexibility at the loading terminal, without compromising safety.

#### SPECIFICATIONS – 8460 SERIES OPTI-THERM

<b>Operating Temperature:</b> -40°F to 158°F (-40°C to 70°C) <b>Input Requirements:</b> 120 VAC 60 Hz, 15VA (Standard); 120 VAC available <b>Output Relay Contacts:</b> 240 VAC – 5A DPDT	<b>Response Time:</b> 0.5 seconds maximum, dry to wet transition <b>Electrical Connections:</b> Internal Terminal Strips <b>Enclosure:</b> NEMA 7 explosion-proof	<b>Housing Material:</b> Aluminum <b>Approximate Weight:</b> Model 8460 – 32 lbs. <b>Approvals:</b> Factory Mutual, CSA	
---	---	---	--

### 8460SRC Opti-Therm/ Scully® Replacement Chassis

The 8460SRC Opti-Therm is a direct replacement chassis for upgrading Scully® ST-6 or BICLOPS® rack monitors with CIVACON™ Opti-Therm technology. Automatic switching and internal ground verification for API optic and thermistor technology are all in one box. Can be used with as many as eight optic or thermistor liquid-level type sensors.

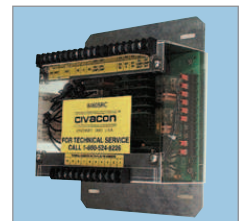

#### SPECIFICATIONS – 8460SRC OPTI-THERM

<b>Operating Temperature:</b> -40°F to 158°F (-40°C to 70°C) <b>Input Requirements:</b> 120 VAC 60 Hz, 15VA (Standard)	<b>OUTPUT RELAY CONTACTS</b> <b>Ground Verified:</b> 240 VAC – 5A DPDT <b>Overflow Permissive:</b> 240 VAC – 5A DPDT	<b>Response Time:</b> 0.5 seconds maximum, dry to wet transition <b>Electrical Connections:</b> Convenient Terminal Strips <b>Housing Material:</b> Aluminum and Lexan®
---	--	---

**IMPORTANT:** OPW products should be used in compliance with applicable federal, state, provincial, and local laws and regulations. Product selection should be based on physical specifications and limitations and compatibility with the environment and materials to be handled. OPW MAKES NO WARRANTY OF FITNESS FOR A PARTICULAR USE. All illustrations and specifications in this literature are based on the latest product information available at the time of publication. OPW reserves the right to make changes at any time in prices, materials, specifications and models and to discontinue models without notice or obligation.

## 8300 Series Thermistor Rack Monitors

The 8300 Series provides automatic warning of product overflow at predetermined levels and warns of impending overflow conditions.

- Uses the standard thermistor signal format to communicate with an onboard control monitor or straight thermistor system on transports.
- Can be used with as many as six (available option of eight) thermistor liquid-level sensors or onboard monitors
- Monitors two-wire Thermo-optic Quick Start™ replacement sensors

**The 8300 Series is available in two models:**

**8340**

Explosion-proof Thermistor Monitor with permissive and non-permissive status lights with keyed bypass switch.

**8360**

Explosion-proof Thermistor Monitor with permissive and non-permissive status lights with keyed bypass switch and ground verification.

In the 8360 monitor, the overfill detection and ground verification are signaled to the pump-control system separately.

### SPECIFICATIONS – 8300 SERIES THERMISTOR RACK MONITORS

<p><b>Operating Temperature:</b> -40°F to 158°F (-40°C to 70°C)</p> <p><b>Input Requirements:</b> 120 VAC 60 Hz, 10 VA (Standard); 240 VAC version available</p>	<p><b>Output Relay Contacts:</b> 240 VAC – 5A DPDT</p> <p><b>Response Time:</b> 0.5 seconds maximum, dry to wet transition</p> <p><b>Electrical Connections:</b> Internal Terminal Strips</p>	<p><b>Enclosure:</b> NEMA 7 explosion-proof</p> <p><b>Housing Material:</b> Aluminum</p> <p><b>Approximate Weight:</b> Model 8340 – 32 lbs, Model 8360 – 32 lbs.</p> <p><b>Approvals:</b> Factory Mutual, CSA</p>
--	---	---

## 8130 Series Optic Rack Monitors

The 8130 Series Optic Rack Monitor can be used with up to eight compatible optic liquid-level sensors or onboard monitors to monitor the status of liquid in transports or other storage tanks.

The 8130 Series uses industry-standard optic signal format. A unique pulsed and intrinsically safe electrical signal is generated by the control panel and transmitted to the sensors via a coiled cord and optic format plug.

**8130**

Explosion-proof optic monitor with status lights. The overfill detection and ground verification are signaled to the pump control system separately. Can also be provided with a by-pass switch, model 8150.

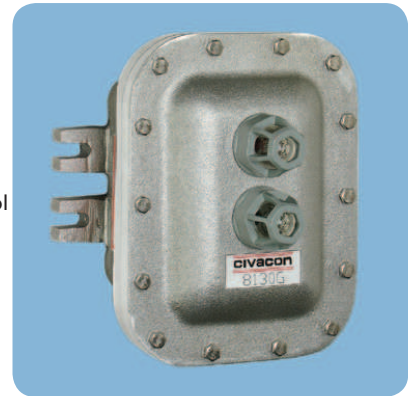

### SPECIFICATIONS – 8100 SERIES OPTIC RACK MONITORS

<p><b>Operating Temperature:</b> -40°F to 158°F (-40°C to 70°C)</p> <p><b>Input Requirements:</b> 120 VAC 60 Hz, 10 VA (Standard); 240 VAC version available</p>	<p><b>Output Relay Contacts:</b> 240 VAC – 5A DPDT</p> <p><b>Response Time:</b> 0.5 seconds maximum, dry to wet transition</p> <p><b>Electrical Connections:</b> Internal Terminal Strips</p>	<p><b>Enclosure:</b> NEMA 7 explosion-proof</p> <p><b>Housing Material:</b> Aluminum</p> <p><b>Approximate Weight:</b> Model 8130 – 32 lbs.</p> <p><b>Approvals:</b> Factory Mutual, CSA</p>
--	---	--

## 8030 Series Ground Verification Monitor

The CIVACON™ model 8030 Ground Verification Monitor is compatible with today's transport ground systems. The monitor is 5 amperage, 240-volt relay output for control of terminal automation systems (TAS), or pump control devices when used as a stand-alone system. The monitor is equipped to provide a permissive signal to allow load rack operation and, if ground is lost, to indicate a non-permissive signal and shut down the loading operation.

### ORDERING SPECIFICATIONS

8030-120 Ground verification monitor with indicator lamps – 120V  
8030-240 Ground verification monitor with indicator lamps – 240V

### OPTIONAL ACCESSORIES

7620-7620 Ground verification plug, dual ball with 30 ft. straight cord  
7690-7690 Ground verification plug, dual ball with 30 ft. straight cord & junction box  
7720-7720 Ground verification clamp with 30 ft. straight cord  
7790-7790 Ground verification clamp with 30 ft. straight cord & junction box



### SPECIFICATIONS – 8030 SERIES GROUND VERIFICATION MONITORS

**Operating Temperature:** -40°F to 158°F  
(-40°C to 60°C)

**Input Requirements:** 120 VAC 60 Hz,  
10 VA (Standard); 240 VAC version  
available

**Output Relay Contacts:** 240 VAC – 5A

**Electrical Connections:** Internal Terminal  
Strips

**Enclosure:** NEMA 4 explosion-proof  
aluminum housing

**Approximate Weight:** Model 8030 – 13 lbs.  
(6 KG)

**Approvals:** UL/CUL Class I, Division I,  
Groups C&D

## Civacon™ Cane Probe

Cane probes are used to provide overfill detection where a permanent sensor cannot be properly affixed to a tank or railcar. They provide a portable, flexible solution to varying overfill requirements for safe top loading. Cane probes utilize modern, instant-on optic principles. Adjusting the sensor position in the tank easily sets the sensing point. This is accomplished with a large adjustment knob on the cane-probe clamp.

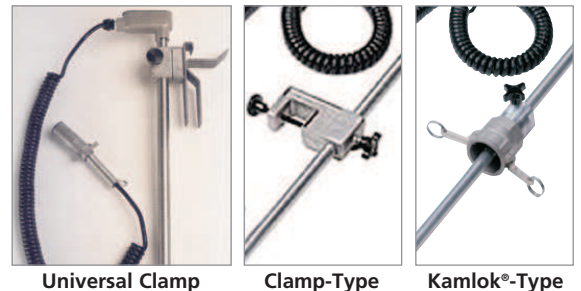

Universal Clamp

Clamp-Type

Kamlok®-Type

## Plug and Cord Sets

CIVACON™ brand plugs and cords are used with junction boxes to connect the overfill-detection monitor to the tank transport at the terminal. Basically, there are two types of systems: optic (blue, 6-pin) and thermistor (green, 8-pin).



## Midland Valve Actuators

OPW Engineered Systems' Valve Actuators are state-of-the-art technology for safe and efficient control of loading and unloading. They provide fast, automated emergency shut-off of loading and unloading valves for handling very hazardous chemicals, such as chlorine or ethylene oxide. When connected to external warning sensors, such as chemical leak detectors, emergency stop switches or vibration and motion sensors, the actuators can immediately (less than 3 seconds) minimize operator exposure and EPA/DOT-reportable releases in the event of a leak in the transfer connections. Automated opening and closing of transfer valves keep workers a safe distance away from hazardous ladings at all times.



**IMPORTANT:** OPW products should be used in compliance with applicable federal, state, provincial, and local laws and regulations. Product selection should be based on physical specifications and limitations and compatibility with the environment and materials to be handled. OPW MAKES NO WARRANTY OF FITNESS FOR A PARTICULAR USE. All illustrations and specifications in this literature are based on the latest product information available at the time of publication. OPW reserves the right to make changes at any time in prices, materials, specifications and models and to discontinue models without notice or obligation.



## Internal Tank Floating Roof Drain Assemblies

OPW Engineered Systems' Floating Roof Drains are designed to provide a better solution to these types of articulated piping. By combining the flexibility of submerged service swivel joints with rigid piping, the system effectively provides positive roof drainage with maintenance-free and worry-free operation. The result is basically a steel pipe drain system with flexible joints capable of withstanding a wide range of service conditions.

### Benefits

- Trouble-free service life with no kinking hose
- No bottom damage due to scraping action
- Ease of operation with sealed swivel joints
- No maintenance due to sediment traps
- No interference with roof legs or other internals

### Features

- Continuous slope design
- 100% aromatic-resistant components
- Small operating area
- Available in sizes 2" and up
- Steel or stainless-steel design available
- High operating pressures
- Standard design includes four swivel joints

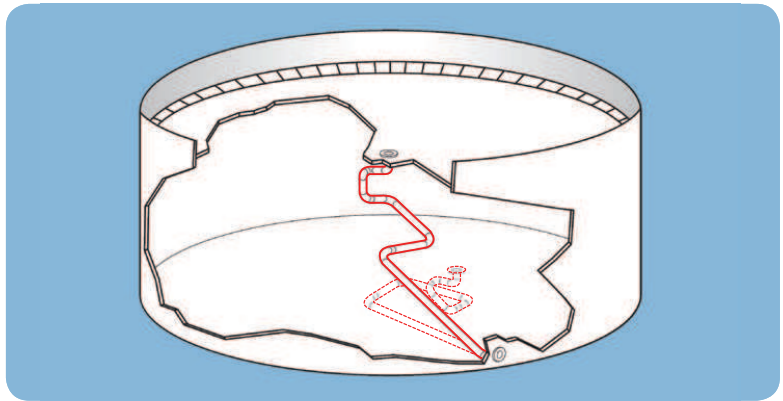

## Submerged Service Swivel Joints



**Style 30FJ**  
Material: Aluminum, Steel, Stainless Steel  
Seals: Buna-N  
Flanges: 150 lb. Raised Face



**Style 40FJ**  
Material: Aluminum, Steel, Stainless Steel  
Seals: Buna-N  
Flanges: 150 lb. Raised Face



**Style 50FJ**  
Material: Aluminum, Steel, Stainless Steel  
Seals: Buna-N  
Flanges: 150 lb. Raised Face

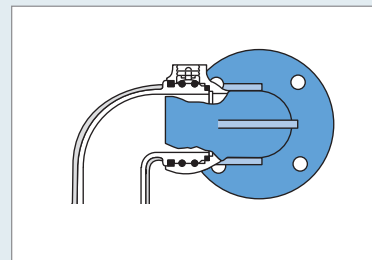

**Triple Seal**

## Internal Tank Floating Suction Assemblies

### 763, 764, 765, 766 Series

OPW Engineered Systems manufactures floating suction assemblies for use in horizontal or vertical, above or below ground storage tanks where little or no contamination can be tolerated, such as aircraft jet fuel. Since the fuel near the top is least likely to contain water or foreign particles, these assemblies are designed to float near the top of the liquid surface and draw from this near-surface, contamination-free liquid. Our floating suctions are engineered for long, trouble-free life.

### Benefits

- Maintenance-free
- Easy movement in the liquid
- Increases efficiency and decreases maintenance of filter separators

### Features

- Permanently lubricated dual race swivel joints
- Triple sealed swivel joints for submerged service
- Suction baffle and stop lag maintains minimum intake level of 8" above tank bottom (or as specified)
- Aluminum 150 lb. flat-faced flanges are standard; steel and stainless steel are available

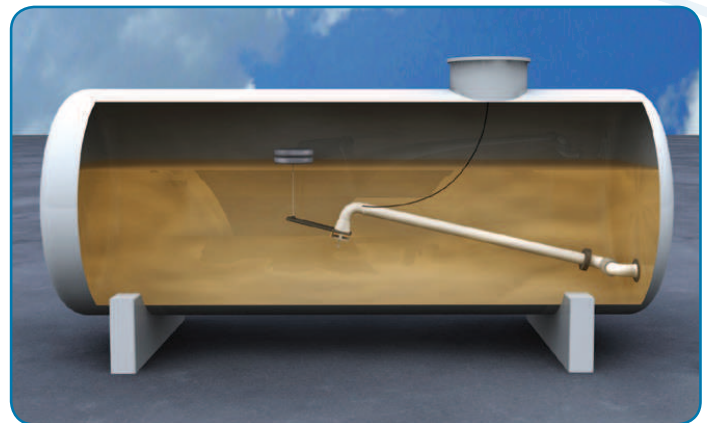
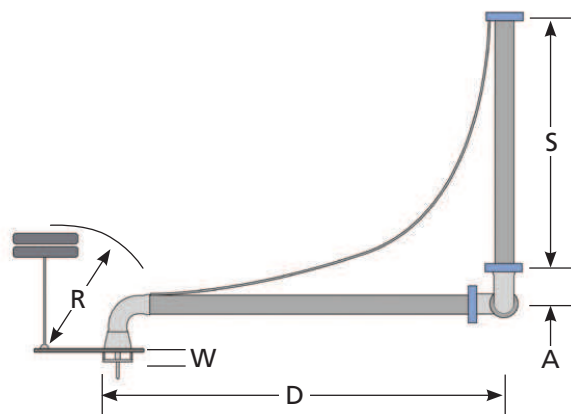

**763:** For tanks under 8' in diameter.

**764:** For tanks 8'-12' in diameter.



**763V:** For tanks under 8' in diameter.

**764V:** For tanks 8'-12' in diameter.



**765:** Single-pipe, extended reach for cone roof tanks.

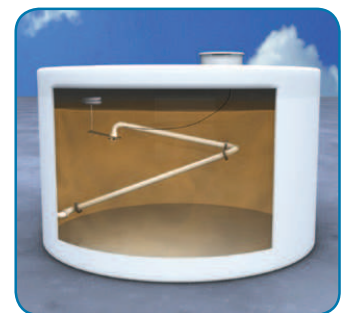

**766:** Scissor-style for large vertical tanks.

### Dimensions (Custom dimensions for Floating Suctions available upon request)

Size		A		D (763)		D (764)		R		W		S (763V)		S (764V)	
in.	mm	in.	mm	in.	mm	in.	mm	in.	mm	in.	mm	in.	mm	in.	mm
2"	51	5-1/2	140	69	1753	121-1/4	3080	28-1/2	714	6-1/2	165	60	1524	108	2743
3"	76	5	127	69	1753	121-1/4	3080	28-1/2	714	6-1/4	159	60	1524	108	2743
4"	102	6-1/16	154	69	1753	121-1/4	3080	28-1/2	714	6-1/2	165	60	1524	108	2743
6"	152	7-3/4	197	69	1753	120-1/8	3051	28-1/2	714	6-3/4	171	60	1524	108	2743

**IMPORTANT:** OPW products should be used in compliance with applicable federal, state, provincial, and local laws and regulations. Product selection should be based on physical specifications and limitations and compatibility with the environment and materials to be handled. OPW MAKES NO WARRANTY OF FITNESS FOR A PARTICULAR USE. All illustrations and specifications in this literature are based on the latest product information available at the time of publication. OPW reserves the right to make changes at any time in prices, materials, specifications and models and to discontinue models without notice or obligation.



**OPW Global Operations**

- 1 OPW Corporate Headquarters
- 2 OPW Fuel Management Systems
- 3 OPW Retail Fueling
- 4 OPW Engineered Systems
- 5 Midland Manufacturing
- 6 Civacon
- 7 PDQ Manufacturing Inc.
- 8 OPW Mexico
- 9 OPW Latin America
- 10 Poland/Petro Vend of Poland, Inc.
- 11 OPW EMEA Headquarters
- 12 OPW EMEA Czech Republic
- 13 OPW FTG Europe
- 14 OPW India
- 15 OPW Asia Pacific
- 16 OPW Russia

