

Dry Gas Filters



PERRY EQUIPMENT CORPORATION

ISO 9001

S E R I E S 3 0
DRY GAS FILTER

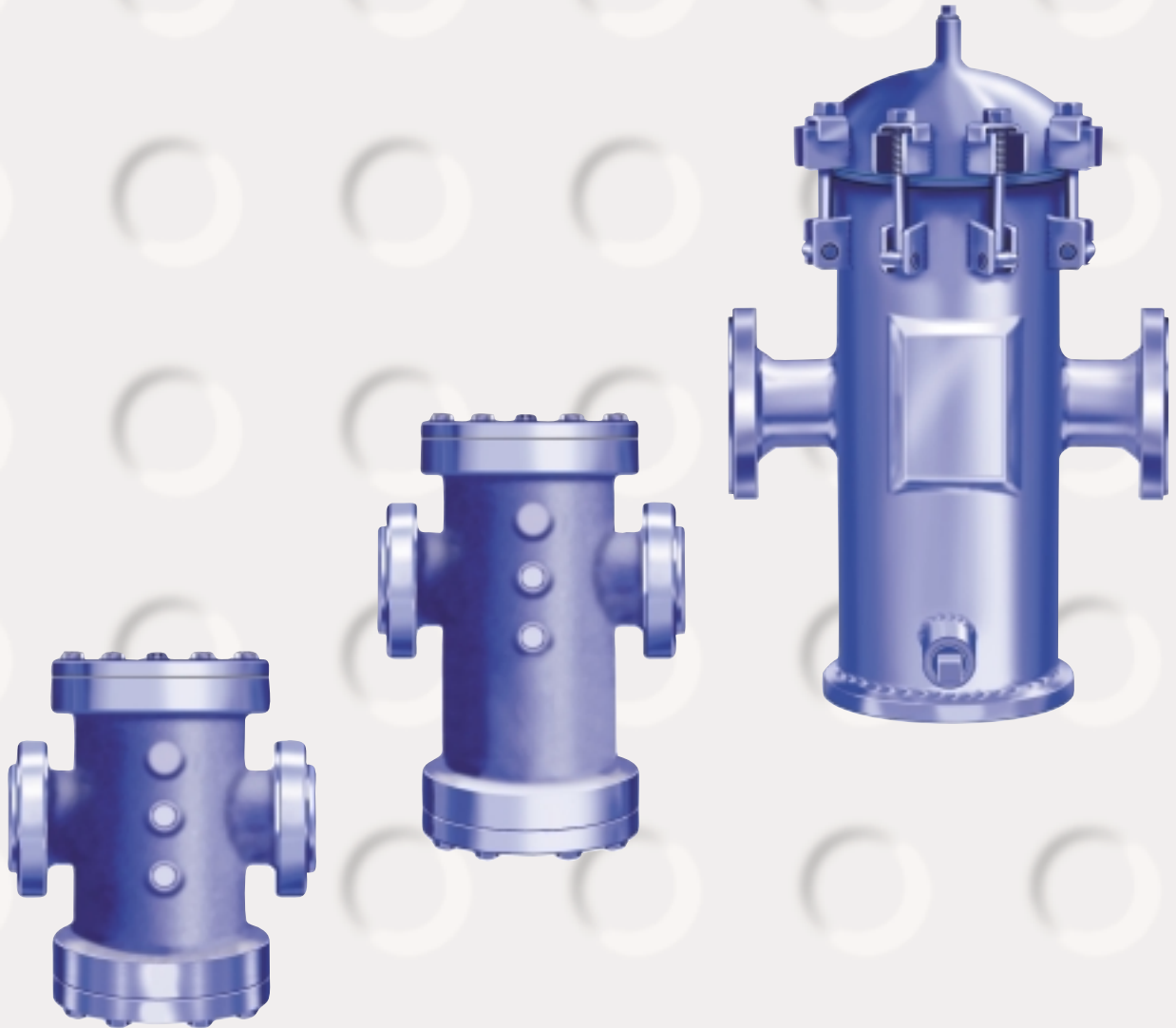

ENGINEERED FILTRATION TECHNOLOGIES

SERIES 30 are engineered to handle *high flow rates*, provide high dirt loading capacities, and deliver high particle removal efficiencies. This performance is achieved utilizing a sturdy yet compact design.

SIZING TABLES SERIES 30/30A CAPACITIES IN CFH (X 1000) at 20" W.C., 14.73 PSIA BASE PRESSURE

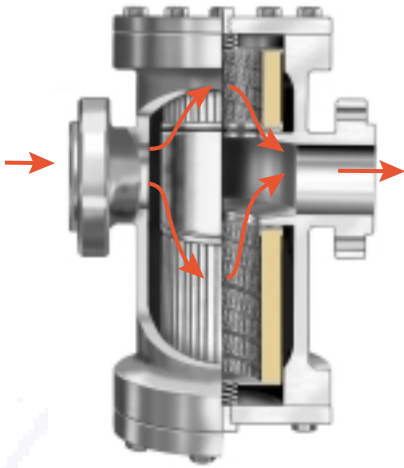

INLET PSIG	Model Numbers								
	30-2-150	30-3-150	30-4-150	30-2-300	30-3-300	30-4-300	30-2-600	30-3-600	30-4-600
0.25	—	—	—	—	—	—	—	—	—
2	25	48	77	25	48	77	25	48	77
5	27	52	84	27	52	84	27	52	84
10	30	58	94	30	58	94	30	58	94
20	36	69	112	36	69	112	36	69	112
40	45	88	141	45	88	141	45	88	141
75	58	112	181	58	112	181	58	112	181
100	66	127	205	66	127	205	66	127	205
150	79	153	246	79	153	246	79	153	246
200	90	174	281	90	174	281	90	174	281
300	109	211	340	109	211	340	109	211	340
400	125	242	391	125	242	391	125	242	391
600	153	295	476	153	295	476	153	295	476
800	176	340	548	176	340	548	176	340	548
1000	196	379	611	196	379	611	196	379	611
1200	214	415	669	214	415	669	214	415	669
1400	231	448	722	231	448	722	231	448	722

TYPICAL APPLICATIONS

- City Gate
- Turbine Meter Installations
- Rotary Meter Installations
- Regulator Stations
- In-plant Filtration
- Fuel Gas

SERIES 30/30A CAPACITIES IN CFH (X 1000) at 1" PSID, 14.73 PSIA BASE PRESSURE

INLET PSIG	Model Numbers								
	30-2-150	30-3-150	30-4-150	30-2-300	30-3-300	30-4-300	30-2-600	30-3-600	30-4-600
0.25	—	—	—	—	—	—	—	—	—
2	29	56	90	29	56	90	29	56	90
5	31	61	98	31	61	98	31	61	98
10	35	68	110	35	68	110	35	68	110
20	42	81	131	42	81	131	42	81	131
40	53	103	166	53	103	166	53	103	166
75	68	132	213	68	132	213	68	132	213
100	77	149	241	77	149	241	77	149	241
150	93	179	289	93	179	289	93	179	289
200	106	205	330	106	205	330	106	205	330
300	128	248	400	128	248	400	128	248	400
400	147	285	460	147	285	460	147	285	460
600	179	347	560	179	347	560	179	347	560
800	207	400	645	207	400	645	207	400	645
1000	231	446	720	231	446	720	231	446	720
1200	252	488	787	252	488	787	252	488	787
1400	272	527	850	272	527	850	272	527	850

SERIES 30/30A CAPACITIES IN CFH (X 1000) at 2" PSID, 14.73 PSIA BASE PRESSURE

INLET PSIG	Model Numbers								
	30-2-150	30-3-150	30-4-150	30-2-300	30-3-300	30-4-300	30-2-600	30-3-600	30-4-600
0.25	—	—	—	—	—	—	—	—	—
2	—	—	—	—	—	—	—	—	—
5	43	83	135	43	83	135	43	83	135
10	49	95	152	49	95	152	49	95	152
20	59	113	183	59	113	183	59	113	183
40	74	144	232	74	144	232	74	144	232
75	96	186	299	96	186	299	96	186	299
100	109	210	345	109	210	345	109	210	345
150	131	253	408	131	253	408	131	253	408
200	149	289	466	149	289	466	149	289	466
300	181	351	565	181	351	565	181	351	565
400	208	403	649	208	403	649	208	403	649
600	254	491	791	254	491	791	254	491	791
800	292	565	911	292	565	911	292	565	911
1000	326	631	1017	326	631	1017	326	631	1017
1200	357	690	1113	357	690	1113	357	690	1113
1400	385	745	1201	385	745	1201	385	745	1201

Flow chart is for natural gas with a specific gravity of 0.65 at 60°F.

SERIES 30A offers an economical alternative to the standard Series 30. Featuring a *lightweight* cast aluminum case, the 30A is rated for ANSI 150 PSI.



SERIES 30F provides the same high flow capacity and compact design as the Series 30 with an added **easy operation** benefit. The swing bolt closure and basket element ensure quick and easy element change-out.

SIZING TABLES SERIES 30F CAPACITIES IN CFH (X 1000) at 20" W.C., 14.73 PSIA BASE PRESSURE

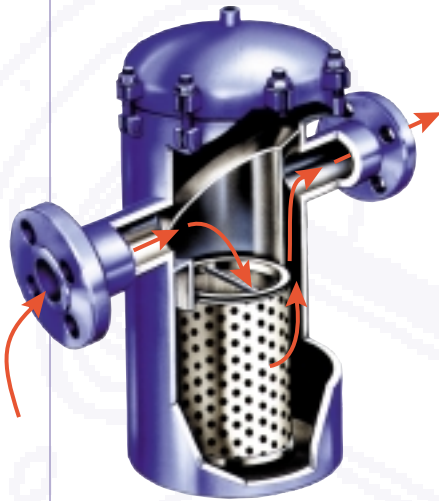

INLET PSIG	Model Numbers							
	30F-1-559-8-2"	30F-1-559-8-3"	30F-1-5519-8-4"	30F-1-819-10-6"	30F-2-5519-16-8"	30F-2-819-20-10"	30F-4-5519-22-10"	30F-3-819-24-12"
0.25	30.32	61.53	77.45	178.10	303.60	515.84	518.90	798.19
2	32.22	65.40	82.31	189.29	322.67	548.25	551.50	848.34
5	33.27	67.52	84.99	195.45	333.17	566.08	569.44	875.93
10	41.00	83.20	104.72	240.82	410.51	697.48	701.63	1079.27
20	48.59	98.61	124.12	285.42	486.54	826.67	831.58	1279.16
40	61.05	123.89	155.94	358.59	611.27	1038.60	1044.77	1607.10
75	78.15	158.60	199.63	459.06	782.54	1329.60	1337.50	2057.38
100	88.36	179.32	225.71	519.05	884.80	1503.35	1512.29	2326.24
150	105.87	214.86	270.44	621.91	1060.14	1801.26	1811.97	2787.22
200	120.87	245.30	308.76	710.02	1210.33	2056.46	2068.68	3182.10
300	146.33	296.96	373.79	859.56	1465.25	2489.58	2504.37	3852.29
400	167.82	340.57	428.67	985.78	1680.40	2855.14	2872.11	4417.96
600	204.37	414.75	522.04	1200.49	2046.41	3477.03	3497.70	5380.25
800	235.31	477.54	601.08	1382.25	2356.24	4003.46	4027.25	6194.82
1000	262.63	532.99	670.87	1542.74	2629.82	4468.29	4494.84	6914.09
1200	287.37	583.18	734.06	1688.03	2877.50	4889.12	4918.18	7565.27
1400	307.23	623.49	784.79	1804.70	3076.37	5227.02	5258.09	8088.13

SERIES 30F CAPACITIES IN CFH (X 1000) at 1" PSID, 14.73 PSIA BASE PRESSURE

INLET PSIG	Model Numbers							
	30F-1-559-8-2"	30F-1-559-8-3"	30F-1-5519-8-4"	30F-1-819-10-6"	30F-2-5519-16-8"	30F-2-819-20-10"	30F-4-5519-22-10"	30F-3-819-24-12"
0.25	35.67	72.38	91.11	209.51	357.15	606.82	610.43	938.98
2	37.91	76.93	96.83	222.68	379.59	644.95	648.78	997.98
5	39.14	79.43	99.98	229.92	391.93	665.93	669.89	1030.43
10	48.23	97.87	123.19	283.29	482.92	820.51	825.39	1269.64
20	57.16	116.00	146.01	335.76	572.36	972.48	978.26	1504.79
40	71.81	145.74	183.44	421.84	719.09	1221.80	1229.06	1890.57
75	91.93	186.57	234.84	540.03	920.57	1564.12	1573.42	2420.27
100	103.95	210.95	265.53	610.61	1040.87	1768.53	1779.04	2736.56
150	124.55	252.76	318.15	731.61	1247.13	2118.99	2131.58	3278.85
200	142.19	288.57	363.22	835.26	1423.82	2419.20	2433.58	3743.39
300	172.14	349.34	439.72	1011.18	1723.70	2928.71	2946.12	4531.80
400	197.42	400.64	504.29	1159.66	1976.80	3358.76	3378.72	5197.23
600	240.42	487.90	614.13	1412.24	2407.38	4090.34	4114.65	6329.27
800	276.82	561.77	707.11	1626.06	2771.86	4709.62	4737.62	7287.52
1000	308.96	627.00	789.21	1814.86	3093.69	5256.45	5287.69	8133.66
1200	338.05	686.05	863.54	1985.78	3385.06	5751.51	5785.69	8899.71
1400	361.42	733.47	923.22	2123.03	3619.01	6149.01	6185.56	9514.78

TYPICAL APPLICATIONS

- City Gate
- Gas Metering
- Pressure Regulation
- Instrument Gas
- Desiccant Removal
- Fuel Gas



Ease of Operation

Eliminate vessel pressure, undo closure bolts, remove head, pull out used element(s), push in new element(s), return head, tighten closure bolts, vent and slowly bring up to line pressure ... and your done.

(Please remember to follow all of your company's safety procedures.)

SERIES 30F CAPACITIES IN CFH (X 1000) at 2" PSID, 14.73 PSIA BASE PRESSURE

INLET PSIG	Model Numbers							
	30F-1-559-8-2"	30F-1-559-8-3"	30F-1-5519-8-4"	30F-1-819-10-6"	30F-2-5519-16-8"	30F-2-819-20-10"	30F-4-5519-22-10"	30F-3-819-24-12"
0.25	50.44	102.37	128.85	296.30	505.08	858.18	863.28	1327.92
2	53.61	108.80	136.94	314.91	536.82	912.10	917.52	1411.35
5	55.35	112.34	141.40	325.16	554.28	941.76	947.36	1457.26
10	68.20	138.41	174.22	400.64	682.94	1160.38	1167.28	1795.54
20	80.84	164.05	206.49	474.84	809.44	1375.30	1383.47	2128.10
40	101.56	206.11	259.43	596.57	1016.95	1727.88	1738.15	2673.67
75	130.01	263.85	332.11	763.72	1301.88	2212.00	2225.15	3422.79
100	147.00	298.33	375.51	863.53	1472.01	2501.08	2515.94	3870.08
150	176.14	357.45	449.93	1034.65	1763.71	2996.70	3014.51	4637.00
200	201.09	408.09	513.67	1181.24	2013.59	3421.26	3441.60	5293.95
300	243.44	494.04	621.86	1430.02	2437.68	4141.82	4166.44	6408.93
400	279.19	566.59	713.17	1640.00	2795.62	4750.00	4778.23	7350.00
600	340.00	690.00	868.51	1997.22	3404.55	5784.62	5819.00	8950.93
800	391.48	794.47	1000.00	2299.60	3920.00	6660.41	6700.00	10306.11
1000	436.93	886.71	1116.11	2566.60	4375.14	7433.74	7477.92	11502.73
1200	478.08	970.22	1221.23	2808.32	4787.20	8133.86	8182.21	12586.09
1400	511.12	1037.28	1305.63	3002.41	5118.06	8696.01	8747.70	13455.94

Flow chart is for natural gas with a specific gravity of 0.65 at 60°F.

Series 30 Construction

Materials Cast Steel
Design ASME Section VIII, Div. I
Pressure Rating 150, 300, 600 ANSI Class
Sizes 2" thru 4" Flanged Connections

Series 30A Construction

Materials Cast Aluminum
Design ASME Section VIII Div. I
Pressure Rating 150 ANSI Class
Sizes 2" and 4" Flanged Connections

Series 30F Construction

Materials Welded Carbon Steel
Design ASME Section VIII, Div. I
Pressure Rating 150—1480 PSIG
Sizes 2" thru 12" Flanged Connections

All models available with ASME code stamp upon request.

Your local distributor:



e-mail:
fs@pecousa.com
web site:
www.pecousa.com

Corporate Offices & Plant

PERRY EQUIPMENT CORPORATION
Wolters Industrial Park
P.O. Box 640
Mineral Wells, Texas 76068
Telephone: 940-325-2575
800-877-PECO
Telefax: 940-325-4622
e-mail: fs@pecousa.com

Houston Branch Office

1758 West Sam Houston Parkway N.
Houston, Texas 77043-3115
Telephone: 713-973-2575
Telefax: 713-467-0475
e-mail: [hou@pecousa.com](mailto:houston@pecousa.com)

Perry Equipment Italiana S.R.L.

via Camozzi, 106
24121 Bergamo (BG)
Italy
Telephone: 3903-523-6340
Telefax: 3903-523-6380
e-mail: peco.italy@tin.it

Perry Operation De Mexico

Parque Industrial Benito Juarez
Acceso III, 4-A
Queretaro, Queretaro, Mexico C.P. 76120
Telephone: 52-42-10-34-89
Telefax: 52-42-10-90-39
Parque Industrial Queretaro
Calle Cerrada La Noria #108
Santa Rosa Jaurequi
Queretaro, Queretaro, Mexico C.P. 76220

Perry Equipment Corporation

S.E. ASIA REGIONAL OFFICE
35-4 Jalan SP2/1
Taman Serdang Perdana, Seksyen2,
43300 Seri Kembangan
Selangor D.E., Malaysia
Telephone: 603-8941-2366
Telefax: 603-8941-1366
e-mail: pecosea@po.jaring.my

Peco Filters, Ltd.

1351 Hastings Crescent S.E.
Calgary, Alberta
Canada T2G-4C8
Telephone: 403-243-6700
Telefax: 403-287-9304
e-mail: fscanada@pecousa.com

European Offices

PERRY EQUIPMENT LTD.
Brunel Business Court
Brunel Way, Thetford
Norfolk IP24 1HP
England
Telephone: 01842 821000
Telefax: 01842 821050
e-mail: sales@perry-equipment.co.uk
www.perry-equipment.co.uk