

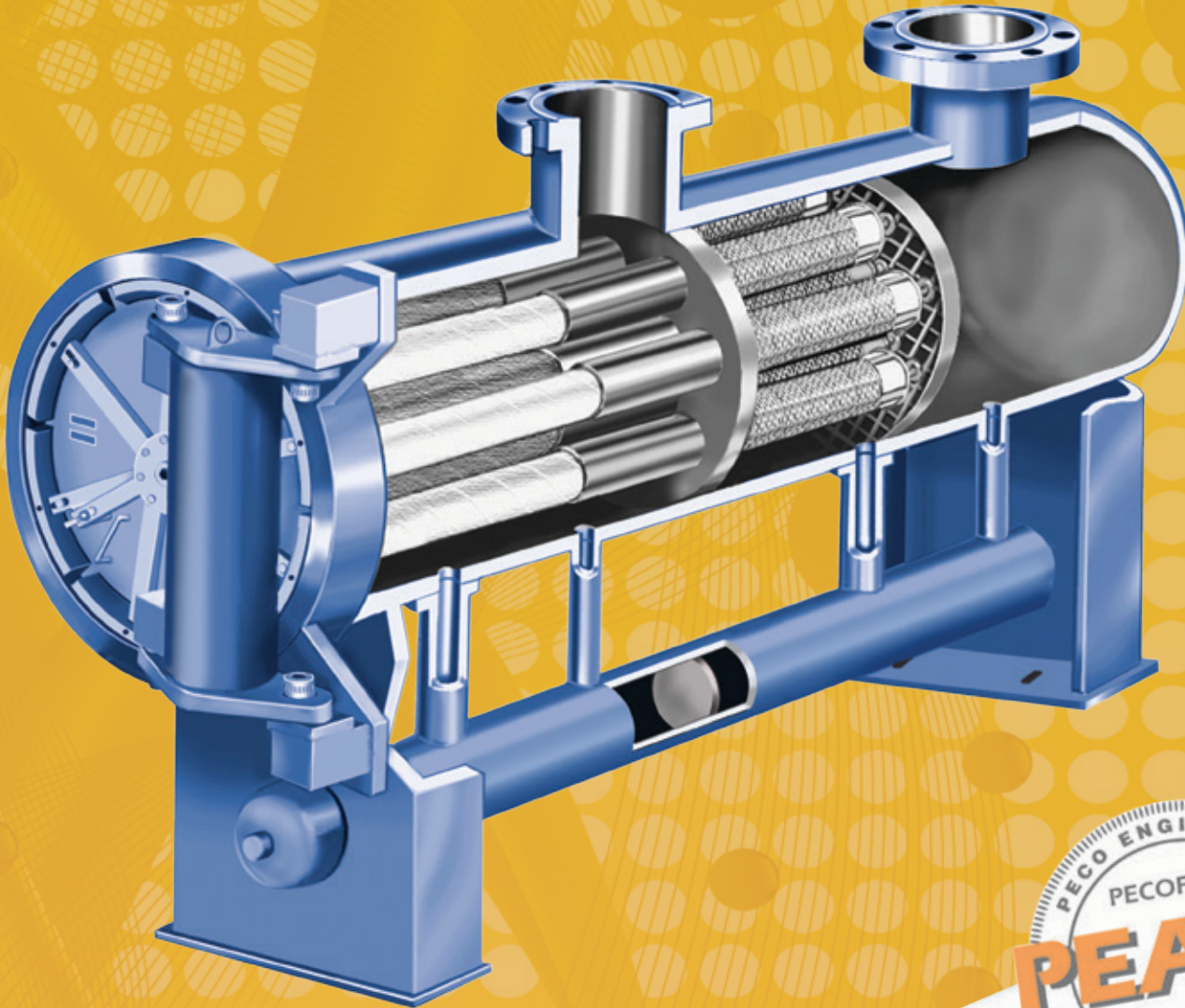

PEACH® Gemini PuraSep®

A NEW ERA IN FILTRATION PERFORMANCE AND INNOVATION™



Innovative Technology for Horizontal Gas Coalescing
28X More Liquid Capacity and **7X** Greater Solids Capacity than a Vertical Coalescer

ISO 9001

PGCPH HOUSING SPECIFICATIONS

Standard Housing

- Custom Design Horizontal Units
- 10" to 72" diameter
- ASME Code Section VIII, Div. 1
- Design temperature from -20°F to 220°F
- Quick Opening Closure
- Pressure Parts: Carbon Steel
- External Attachments: Carbon Steel
- Hydrostatic testing at 1.3 x design pressure
- Full diameter flanged sump clean-outs on stock units
- Comes with PEACH® Gemini (Model PGC) filter/coalescer cartridges in polyester at 0.3 micron rating with standard performance level and Buna-N seal. 73", 82" or 94" lengths

Options

- Other Design Codes
- Design Pressure up to 5,000 psig
- Materials of Construction
 - 304 Stainless Steel
 - 304L Stainless Steel
 - 316 Stainless Steel
 - 316L Stainless Steel
 - Low Temperature Materials
- Non-Destructive Testing (NDT)
 - Radiography
 - Magnetic Particle
 - Liquid Penetration
 - Ultrasonic
 - Brinell Hardness
 - Charpy Impact
- Coating options
 - Sandblast: commercial, near white and white metal
 - Paint: 2 & 3 coat corrosion resistant
- Optional PECO SafeLock Closure®
- Auxiliary Packages in Stock
- PEACH® Gemini filter/coalescer cartridge options
 - Polypropylene media
 - Metal core
 - PL-20 performance level
 - EPDM or Viton® seal



FEATURES

- **0.3 Micron High Efficiency Coalescing**
The PEACH® Gemini PuraSep® provides 28 times more liquid capacity and 7 times greater solids capacity than a vertical coalescer.
- **Horizontal Configuration**
Provides easy ground access to auxiliary controls and cartridges without the need for ladders and platforms.
- **100% turndown**
PEACH® Gemini PuraSep® can be operated from 0% to 100% of its rated capacity without any effect on performance.
- **Quick Opening Closures**
Easy and quick access to all internal parts is made available via a yoke/clamp style Quick Opening Closure or internal door style PECO SafeLock Closure®.
- **User Friendly Design**
Designed to provide trouble-free maintenance, the PEACH® Gemini PuraSep® internals are easy to remove and replace. The second stage LIB's are removable to make second stage inspection effortless. The bayonet cartridge design eliminates the need for hand tools when sealing.

IMPROVE RELIABILITY with PEACH® Gemini PuraSep®

The PEACH® Gemini PuraSep® is another PECOFacet innovative product for the oil and gas industry. Specifically designed around patented PEACH® technology, the housing/cartridge combination was developed to offer superior performance, flexibility, and a remarkably trouble-free design - unlike any filter/coalescing equipment currently available.

First of its kind
Horizontal
Gas Coalescer



INNOVATIVE TECHNOLOGY



The PEACH® Gemini PuraSep® utilizes two stages of coalescence in a single PEACH® cartridge. Gone is the conventional 2nd stage mist eliminator along with the worries about the type of 2nd stage needed for various liquid contaminants. The PEACH® Gemini coalescing cartridge is compatible with, and efficiently coalesces, liquid contaminants encountered in the oil & gas industry, including low surface tension liquids.

The PEACH® Gemini PuraSep® delivers ultra-clean gas with high efficiency removal of solid and liquid contaminants. It effectively handles higher inlet solid and liquid loads than conventional gas coalescers. Two stages of coalescing and separating are contained in a single, replaceable PEACH® Gemini cartridge.

TYPICAL APPLICATIONS

- Compressor Suction and Discharge
- Contactor Carryover
- Fired Reboilers
- Gas Analyzer
- Gas Injection System
- Landfill Gas
- Line Heaters
- Propane Refrigeration System
- Solid Dessicant or Molecular Sieve Beds
- Turbine Fuel Gas
- Metering Stations
- Plant Feed
- Low NOx Burner Tip Protection

PEACH® Gemini PuraSep® Operation

The PEACH® Gemini PuraSep® utilizes a single tube configuration PEACH® PGC cartridge with a chevron seal, which seats inside the riser tube and separates the two primary stages of coalescing. This design ensures a smooth transition of coalesced liquids from the 1st stage into the 2nd stage.

- Incoming liquids pass outside-to-inside through the first section of the PGC cartridge where solids are filtered and 1st stage liquid coalescing takes place. Large liquid droplets are removed in the 1st stage and collected in the 1st stage sump compartment.
- The gas, along with lighter coalesced liquids, then passes into the 2nd stage area of the PGC cartridge where they flow from inside-to-outside, causing them to be coalesced for a second time.
- A specially designed liquid impingement baffle (LIB), placed over the 2nd stage section of the PGC cartridge, captures the coalesced liquids along its surface where they drop out, due to gravity, and are collected in the 2nd stage sump compartment.
- The LIB directs the gas flow to the end of the PGC cartridge to yield a final scrubbing effect. The clean gas exits the housing through the outlet nozzle.

TRUE HORIZONTAL COALESCER

Removes 99.9% of solids
0.3 micron and larger.
Removes 99.5% of liquids
0.3 micron and larger.

Laboratory and field performance validated, under isokinetic conditions, with laser particle counter technology.

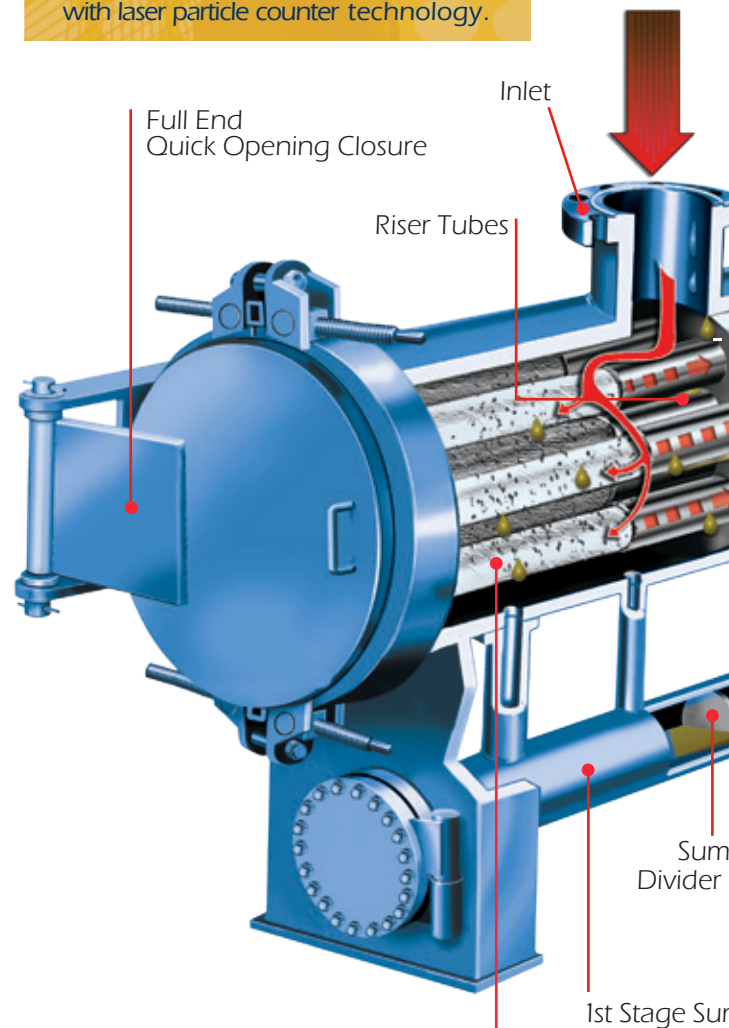

Cartridge Model PGC

Available in polyester or polypropylene media with various performance level recipes at 0.3 micron rating.

ADVANCED

The PEACH Gemini PuraSep® is rigid enough to maintain pressure and the PGC cartridge (helical) flow depth of the scrubbing effect. The depth of the scrubbing effect is the depth of the scrubbing effect.

The PGC Coalescing structure varies with depth and gravity when a low difference in density is present.

COALESCER
of solids
larger.
of liquids
larger.

performance
tic conditions,
r technology.

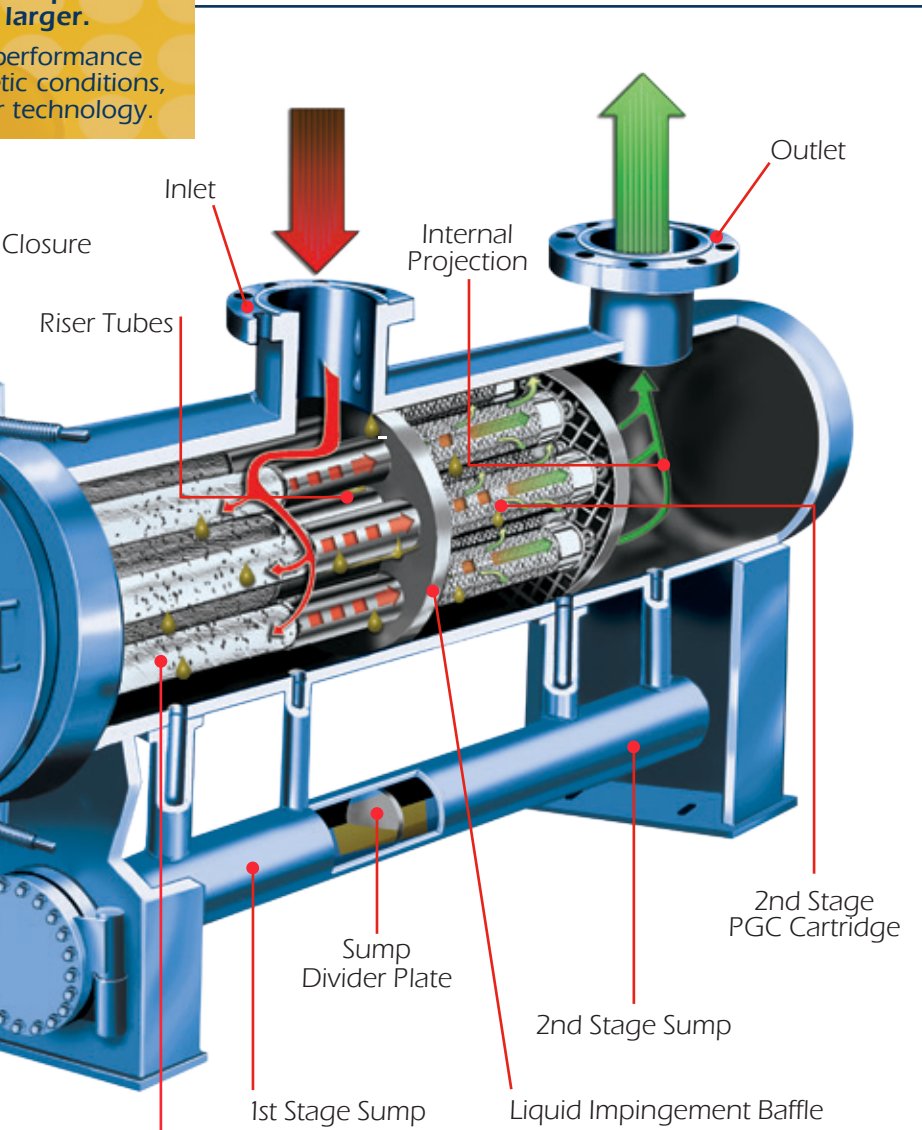

User Friendly Design

The operation of the PEACH[®] Gemini PuraSep[®] is simple and trouble-free, allowing users to minimize their operating and maintenance cost.

- PGC cartridges have fixed bayonet ends. There is no torque of end caps or nuts to remove and reinstall when changing out cartridges.
- The Gemini contains a lightweight mounting plate with handles that easily fits over the bayonet end caps of the cartridges.
- There are no rigid cartridge support assemblies to maneuver the cartridges over, or to hinder removal. The PGC cartridge easily slides into place via the self-centering riser tubes mounted in the support plate.
- There are fewer cartridges to replace. The gas flow capacity of each PGC cartridge is higher than conventional vertical Gas Coalescers or Filter Separators.

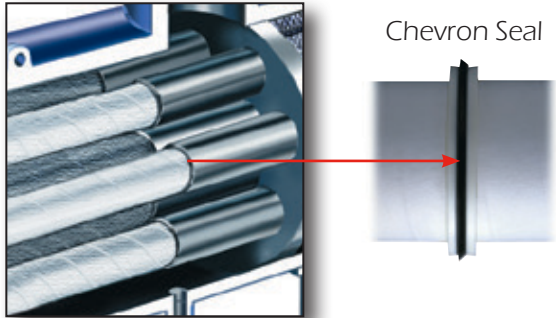

POSITIVE SEALING
Each PGC cartridge contains an integral sealing ring with a built-in chevron seal which seals within the 1st stage riser tube. Differential pressure between the 1st and 2nd stage compartments assures constant positive sealing with no bypass.

ADVANCED TECHNOLOGY CARTRIDGES
The PEACH[®] Gemini PuraSep[®] uses the unique, patented PEACH[®] Gemini cartridge technology. PGC cartridges are rigid enough to withstand abrasion and heavy liquids, yet maintain porosity and permeability for lower differential pressure and extended contaminant removal capacity. PGC cartridges also provide a torturous (axial, radial and helical) flow path for the wet gas to take through the depth of the media, increasing the probability for contaminant particles to impact fibers and be captured throughout the depth of the media.

The PGC cartridge uses the concept of Saturated Depth Coalescing[™] to provide an open 3-D depth matrix structure which allows liquids to saturate the media depth and grow to fullest potential, then drain with gravity when the droplet is ready, all while maintaining a low differential pressure.

propylene media
el recipes at 0.3



World Headquarters

PECOFacet (US), Inc.
 P.O. Box 640
 Mineral Wells, Texas 76068

Phone: 940-325-2575
 Toll Free: 800-877-7326
 Fax: 940-325-4622

Oil & Gas Technology Center

Mineral Wells, Texas

For inquiries email:
sales@pecofacet.com

Visit our website to find:

- An office location near you
- Installation & Operating Instructions
- Housing registration form
- Associated cartridge information
- Most current literature editions

pecofacet.com

FIELD PROVEN RESULTS



PECOFacet is a world leader in the design and manufacture of quality Filtration Equipment, specializing in the Oil and Gas Industry.

Founded in 1936, many of the filtration technologies used in the Industry today were originally developed by PECOFacet.

Our continued dedication to research and development of new advanced technologies has kept PECOFacet at the forefront of Engineered Filtration Solutions for use by our clients worldwide.

**YOUR
 CONTAMINANT
 MANAGEMENT
 PARTNERSM**

Stock Units available from 10" through 60" diameter in 600# ANSI rating.

HOUSING ORDERING INFORMATION

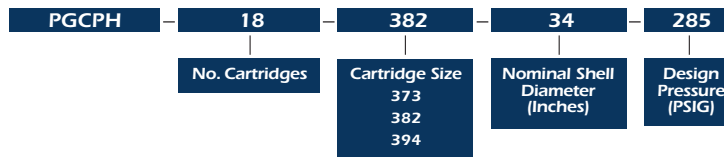

Refer to the following data sheet for detailed cartridge information:
 PEACH® Gemini cartridges.