

Ball valve for manifold mounting Steel

PKH

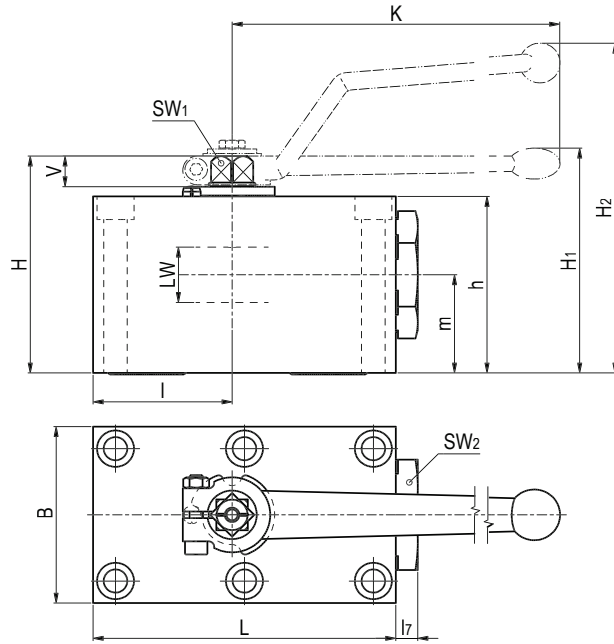

AVAILABLE SIZES

DN6 - DN50 (1/4" to 2")

ACCESSORIES ON REQUEST

- Locking devices page 229
- Actuators 224 - 225
- Position switches on request
- Detent on request

MATERIAL CODE DESCRIPTION

Materials	112A	1128
Body	Steel	Steel
Ball	Steel	Steel
Stem	Steel	Steel
Ball seats	POM	POM
O-rings	NBR	FPM
Tmin / Tmax	-20°C / 100°C	-20°C / 100°C

GENERAL DIMENSIONS

Type	I	L	I ₇	B	H	h	m	V	SW ₁	SW ₂	K	LW	H ₁	H ₂	Lever	Weight [Kg]
PKH-DN6	26	57	6	40	43	35	19,5	6	7	19	80	6	-	67	Zn	0,60
PKH-DN10	29	70	10	55	59	45	24,5	11	9	30	115	10	-	93	Zn	1,30
PKH-DN13	42,5	98	10	60	69	55	34	11	9	32	115	13	-	104	Zn	2,30
PKH-DN16	44	100	9,5	60	72,3	55	28	14	12	36	160	16	-	115	Al	3,75
PKH-DN20	51	117	10	70	88	70	37,5	14	14	46	200	20	92	-	Zn	3,92
PKH-DN25	62	135	10	80	98	80	44,5	14	14	50	200	25	102	-	Zn	5,68
PKH-DN32	75	165	11	100	121	100	54,5	17	17	70	320	32	130	-	Al	11,00
PKH-DN40	84,5	200	17	130	131	110	57	17	17	80	320	38	140	-	Al	18,78
PKH-DN50	106	240	15	150	150	129	71	17	17	90	320	48	159	-	Al	29,70

CONNECTION

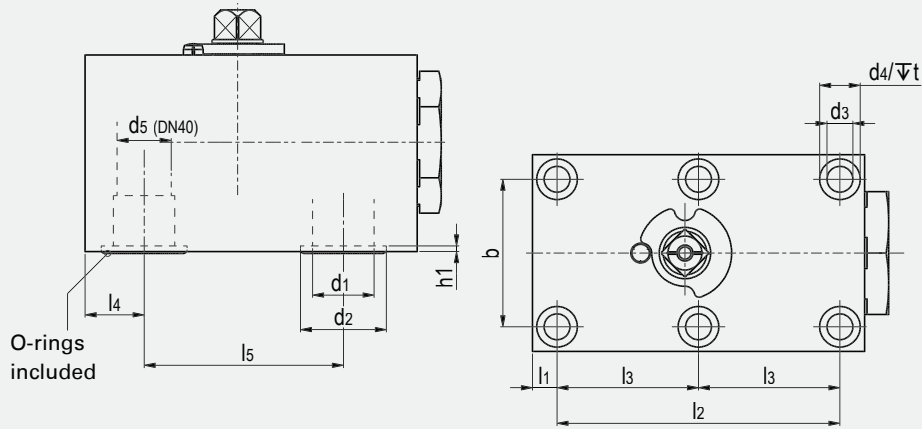

CONNECTION DIMENSIONS

Type	l_1	l_2	l_3	l_4	l_5	b	d_1	d_2	h_1	d_3	d_4	t	d_5	Dimension of screws (min) ⁽¹⁾	Torque of screws in Nm ⁽¹⁾	O-ring	ORDER CODE PER MATERIAL COMBINATION		
																	PN [bar]	112A	1128
PKH-DN6	8,5	35	-	8,5	35	27	6	11,8	1,9	6,5	10,5	6,8	-	4 x M6x40 - 12.9	14	7x2,5	500	22661*	28416*
PKH-DN10	7,5	55	-	10	44	40	9,5	14,9	1,9	8,4	13,5	8,5	-	4 x M8x50 - 12.9	35	10x2,5	500	28687*	15727*
PKH-DN13	7,5	83	41,5	16	58	45	13	24,9	1,9	8,4	13,5	7	-	6 x M8x60 - 12.9	35	20x2,5	420	29571*	29226*
PKH-DN16	8,5	83	41,5	16	58	45	13	24,9	1,9	8,4	13,5	9	-	6 x M8x60 - 12.9	35	20x2,5	400	on request	
PKH-DN20	10	97	48,5	20	69	51	20	29	2	10,5	16,5	10,5	-	6 x M10x80 - 12.9	70	23,47x2,62	420	29296*	29292*
PKH-DN25	10	115	57,5	24	81	60	25	34,9	2,3	10,5	16,5	10,5	-	6 x M10x90 - 12.9	70	29x3	420	28953*	26334*
PKH-DN32	12	136	68	29	96	78	32	40	2	13	19	12	-	6 x M12x110 - 12.9	110	34,59 x 2,62	420	59599	59600
PKH-DN40	28,5	112	56	28,5	112	95	38	47,7	2,3	16,5	25	19	36	6 x M16x120 - 12.9	300	42x3	420	28331*	31261*
PKH-DN50	38	136	68	38	136	112	48	59,8	2,3	21	31	21,5	-	6 x M20x140 - 12.9	600	54x3	420	28338*	32267*

*Article usually in stock.

⁽¹⁾ Fixing screws not included.

We recommend screws as per ISO4762 (DIN 912).

The indicated property classes and torques represent our recommended guidelines at a friction coefficient of 14%.

Due to material availability the material code of the steel valves may vary from 112A (or 1128). DN6=1123 (or 1125), DN32=212A (or 2128), DN40-50=812A (or 8128). Material suitability for the application does not differ from 112A (or 1128).

FLOW CHARACTERISTICS PKH

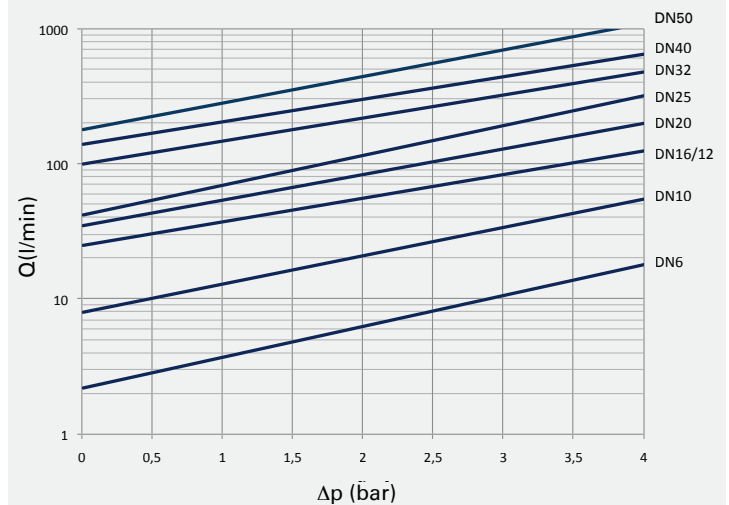

Ball valve for manifold mounting Stainless Steel

PKH

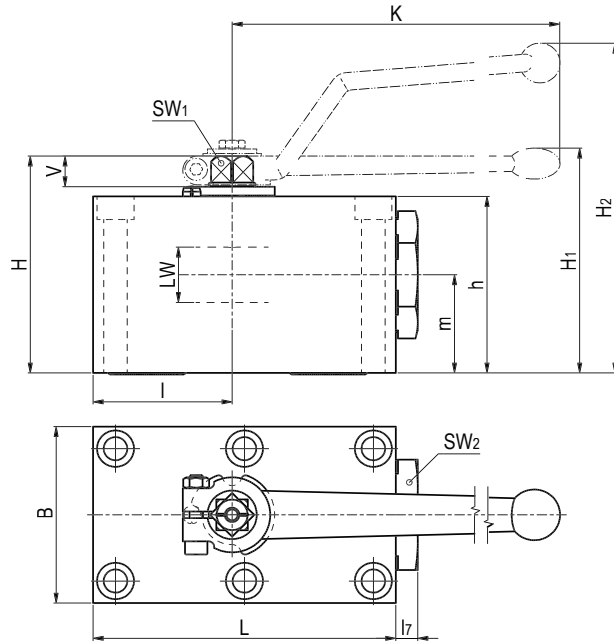

AVAILABLE SIZES

DN6 - DN50 (1/4" to 2")

ACCESSORIES ON REQUEST

- Locking devices page 229
- Actuators 224 - 225
- Position switches on request
- Detent on request

MATERIAL CODE DESCRIPTION

Materials	442A	4428
Body	Stainless Steel	Stainless Steel
Ball	Stainless Steel	Stainless Steel
Stem	Stainless Steel	Stainless Steel
Ball seats	POM	POM
O-rings	NBR	FPM
Tmin /Tmax	-30°C / 100°C	-20°C / 100°C

GENERAL DIMENSIONS

Type	I	L	l ₇	B	H	h	m	V	SW ₁	SW ₂	K	LW	H ₁	H ₂	Lever	Weight [Kgl]
PKH-DN6	26	57	6	40	43	35	19,5	6	7	19	80	6	-	67	Zn	0,60
PKH-DN10	29	70	10	55	59	45	24,5	11	9	30	115	10	-	93	Zn	1,30
PKH-DN13	42,5	98	10	60	69	55	34	11	9	32	115	13	-	104	Zn	2,32
PKH-DN20	51	117	10	70	88	70	37,5	14	14	46	200	20	92	-	Zn	4,02
PKH-DN25	62	135	10	80	98	80	44,5	14	14	50	200	25	102	-	Zn	5,70
PKH-DN32	75	165	11	100	121	100	54,5	17	17	70	320	32	130	-	Al	11,00
PKH-DN40	84,5	200	17	130	131	110	57	17	17	80	320	38	140	-	Al	18,78
PKH-DN50	106	240	15	150	150	129	71	17	17	90	320	48	159	-	Al	29,55

CONNECTION

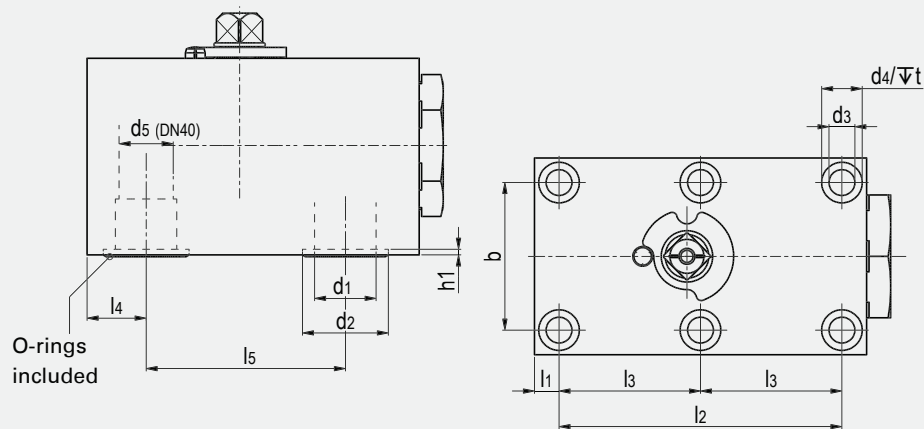

CONNECTION DIMENSIONS

Type	l ₁	l ₂	l ₃	l ₄	l ₅	b	d ₁	d ₂	h ₁	d ₃	d ₄	t	d ₅	Dimension of screws (min) ⁽¹⁾	Torque of screws in Nm ⁽¹⁾	O-ring	ORDER CODE PER MATERIAL COMBINATION		
																	PN [bar]	442A	4428
PKH-DN6	8,5	35	-	8,5	35	27	6	11,8	1,9	6,5	10,5	6,8	-	4 x M6x40 - 12.9	14	7x2,5	500	21337	28244
PKH-DN10	7,5	55	-	10	44	40	9,5	14,9	1,9	8,4	13,5	8,5	-	4 x M8x50 - 12.9	35	10x2,5	500	10053	29747
PKH-DN13	7,5	83	41,5	16	58	45	13	24,9	1,9	8,4	13,5	7	-	6 x M8x60 - 12.9	35	20x2,5	420	25439	18041
PKH-DN20	10	97	48,5	20	69	51	20	29	2	10,5	16,5	10,5	-	6 x M10x80 - 12.9	70	23,47x2,62	420	28598	38365
PKH-DN25	10	115	57,5	24	81	60	25	34,9	2,3	10,5	16,5	10,5	-	6 x M10x90 - 12.9	70	29x3	420	33708	32060
PKH-DN32	12	136	68	29	96	78	32	40	2	13	19	12	-	6 x M12x110 - 12.9	110	34,59 x 2,62	420	59601	59602
PKH-DN40	28,5	112	56	28,5	112	95	38	47,7	2,3	16,5	25	19	36	6 x M16x120 - 12.9	300	42x3	420	36117	38367
PKH-DN50	38	136	68	38	136	112	48	59,8	2,3	21	31	21,5	-	6 x M20x140 - 12.9	600	54x3	420	38368	38369

⁽¹⁾ Fixing screws not included.

We recommend screws as per ISO4762 (DIN 912).

The indicated property classes and torques represent our recommended guidelines at a friction coefficient of 14%.

FLOW CHARACTERISTICS PKH

