

# FM 40

## FLANGE MODULE

### Maximum flexibility in use and performance

**UVpro FM** flange modules are available as mono and duo devices. The modules are ideal for first-time or subsequent installation in air ducts, storage tanks as well as surface treatment in crate washers etc. Especially the variety of possible applications, the high reliability and the easiness of installation makes it to our all-rounder.

---

**For air ducts, tanks, basins, in facilities etc.**

---

**Suitable for full immersion (IP68)**

---

**Easy installation, also subsequently**

---

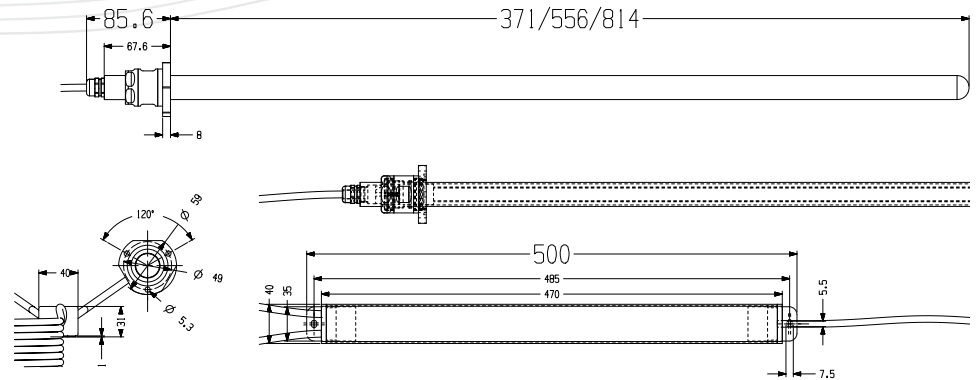

## SPECIFICATIONS

Short name	UVpro FM		
In conformity with requirements	EMC, CE, IP68		
Material	stainless steel: WN 1.4301 and WN 1.4305		
Operating temperature [°C]	0...+40		
Suitable UVpro tube	UVpro K(T)20-4	UVpro K(T)30-4	UVpro K(T)40-4
Type [mono / duo]	UVpro FMM 40 / UVpro FMD 40		
Input power [W]	21 / 42	31 / 62	41 / 82
Current flow [mA]	110 / 210	145 / 290	195 / 390
Total UVC output [ $W_{253.7\text{ nm}}$ ]	7 / 14	11 / 22	14 / 28
Tube intensity at 1 m [ $\mu\text{W}/\text{cm}^2$ ]	65	95	145
Tube length from screw joint [mm]	371	556	814
Weight [kg]	2.65 / 3.2	2.7 / 3.25	2.75 / 3.3
Screw joint, wrench size [mm]	34		
Tube replacement interval [h]	12,000 (75 % <sup>+5%</sup> output performance)		
Life expectancy electronics	> 10 years		
Supply voltage [ $V_{AC}$ ]	220...240 (50...60 Hz)		
Cable length, grid / tube [m]	10 (customisable) / 1		

## Application Optimised UV for



Food & Beverage  
Industrial UV



Healthcare  
Industrial UV



Pharmaceuticals  
Industrial UV



### Canada

+1 980.256.5700  
americas@nuvonicuv.com

### United Kingdom

+44 1753 515300  
emea@nuvonicuv.com

### China

+86 21 61679599  
apac@nuvonicuv.com

### USA

+1 980 256 5700  
americas@nuvonicuv.com

### Germany

+49 (0)2268 908300  
info@nuvonicuv.de

### Malaysia

+60 16 440 8834  
sea@nuvonicuv.com

### Mexico

+1 980.256.5700  
americas@nuvonicuv.com