

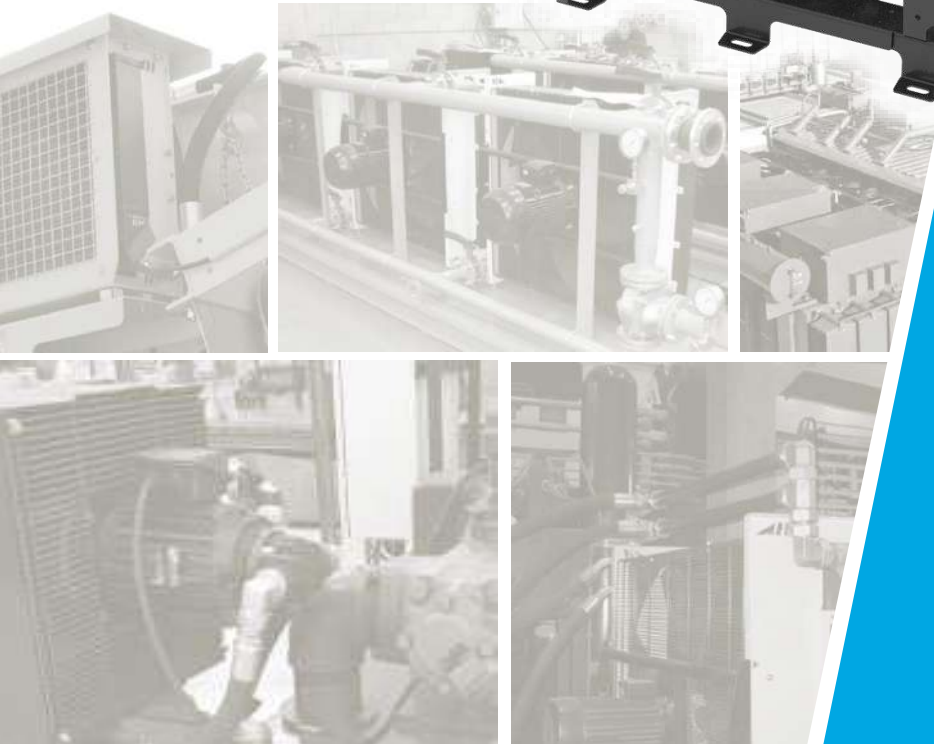

Thermal Systems

Fluid Controls

Modular Cooler Unit – MCU



**be different.
make a difference.**

Fluid Controls

Air Cooled Range / Water Cooled Range



Design

The modular cooling unit (MCU) has been developed to offer a compact off-line cooling solution that combines high performance pumps and heat exchangers with an adjustable steel frame. This highly flexible system can be used to create the best solution for most off-line circuits, e.g. for lubrication, cooling or filtration. The MCU comes with our generator generation 2 pump technology and offers 5 different displacements in combinations with the best suitable AC motors. You can choose between an air blast oil cooler or two different heat exchangers such as Shell & Tube and brazed plate heat exchangers. Please contact us to discover the huge potential of this system and select the optimal configuration for your application.

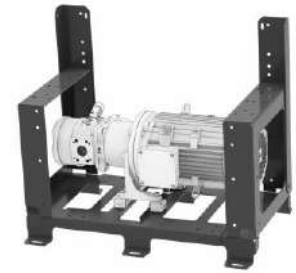

Advantages

- Complete system for quick installation
- Compact design to save space.
- Robust design for durable use in heavy duty industrial fields.
- Best cooling designed with comprehensive research & development.
- Short-term availability through modular standard parts.
- The asa rail system is an additional option to the conventional SAE 1 1/4" connection on the pump outlet. The system requires a connector kit which can be turned in 4 different directions and offers an additional BSP 1/2" port for any monitoring or other purpose.
- Our standard range of plate heat exchangers covers a wide performance spectrum to ensure competitive pricing, high quality and short lead times.
- The other water cooled options with shell and tube heat exchangers, which can also be used with process water to reduce clogging situations.
- High reliability

Characteristics

- Circulation unit with low pulsation and included cooling function
- Optional filter integration
- High performance cooling systems with ambient air or water
- Fan and pump are driven with three-phase motors
- Universally applicable to hydraulic oil, gear oil, coolant and lubrication oil circuits
- Maximum pump outlet pressure up to 10bar (relative)

Applications

The asa modular cooling unit (MCU) is designed for low pressure off-line cooling, filtration and lubrication circuits with hydraulic oil, gear oil, engine oil and lubrication oil in industrial applications.

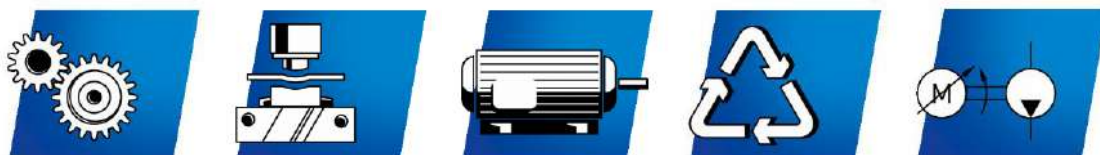

This data sheet and the corresponding CAD drawings are to be used as a general guideline and technical overview of our products. Please contact us if more exact information is needed. As we are constantly improving our products, the characteristics, dimensions and weights may also change, although we do our best to incorporate these changes continuously. asa assumes no liability for any information, drawings, impressions, misprints, non-optimized or indirect damages, losses or costs resulting therefrom. Any cooling performance and general technical values indicated in this catalogue are measured at a test bench according to standard test procedures or calculated, based on such tests. They represent a basis for your purchase decision. Due to different conditions in testing and application environments the performance may also vary by up to 15%. All sound values are determined in accordance with ISO 9614-2, DIN EN ISO 11203 accuracy class C or Machinery Directive 2006/42/EG and are Average. As some of the performance data, possible differences to comparison data are possible. The reason for that are no existing standard test procedures or individual suggestions, e.g. for cooling performance measurements. Therefore, we recommend all products to be checked under the system operating conditions. This also applies to vibrations and mechanical stress as well as for pressure peaks and thermal stress and any other relevant factors. General tolerances according to DIN ISO 2768-Ms. General tolerances for casted parts according to DIN ISO 3092-3 (DIN 3010). Tolerances for rubber parts are according to ISO 3302-1 (class V4-F100). The tolerances of welding seams are defined by quality group D according to DIN ISO 5817. If it is not specified on the actual CAD drawing or data sheet. Any form of liability is excluded for the information included in this data sheet. All details and calculation values are checked to the best of our ability, but these do not ensure any intrinsic product compatibility due to the wide ranging possible applications. It is advised that additional data relevant to the product itself, such as the end user, asa technology Productions and Vertrieb GmbH reserves the right to modify the product without any separate notification. This refers to both technical data and the product itself. Furthermore, it should be specified that the catalogues does not substitute the corresponding CAD drawings, assembly and installation drawings or the operating instructions. 00-Modular-Cooler-Unit-MCU-en-160
© asa technology, November 2023 page 2/2

Fluid Controls

Air Cooled Range / Water Cooled Range



Order Code

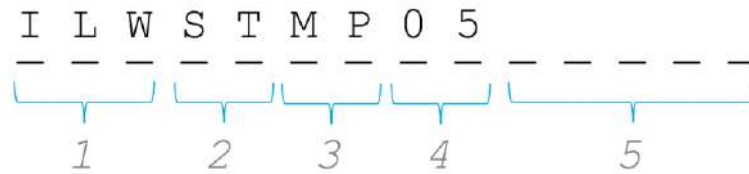

1 Product Category

II I	oil/air cooling
II W	oil/water cooling

2 Product Series

II	II rail series
PI	plate heat exchanger series
SI	shell & tube series

3 Product Series

MP	motor pump
----	------------

4 Cooler Size

2b	II III
36	
4b	
53	II WPI
6b	
70	II WSI
03	
0b	

5 Customized

-----	drawing no.
-------	-------------

Pump option:

- 20 cm³
- 32 cm³
- 40 cm³
- 60 cm³
- 80 cm³

Motor option:

- 1.10 kW
- 1.50 kW
- 2.20 kW
- 3.00 kW
- 4.00 kW

Standard components of adjustable frame

Cooler option:

- ASA1125RA...
- ASA1136RA...
- II WPI /5.../FP
- II WPI /53.../FP
- II WPI /65.../FP
- II WPI /70.../FP
- II WSI ...032/...
- II WSI ...0b18...
- II WSI ...0b2/...

Other option:

Filter installation options:
Oil/Water Cooler/Pump Unit

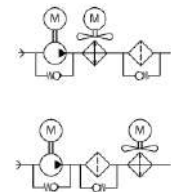

Connection options:

- II I /AI1153G2b
- II I /AI1153G3?

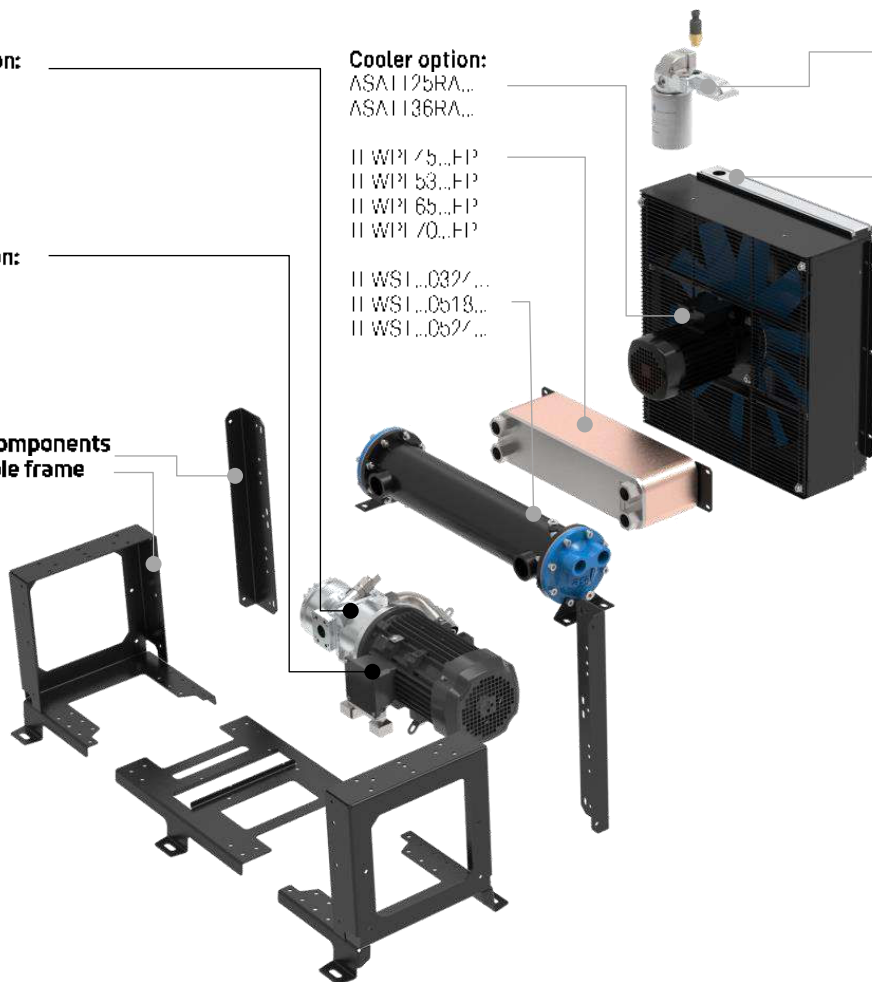
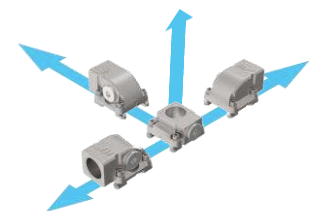

This data sheet and the corresponding CAD drawings are to be used as a general guideline and technical overview of our products. Please contact us if more exact information is needed. As we are constantly improving our products, the characteristics, dimensions and weights may also change, although we do our best to incorporate these changes continually. asa assumes no liability for any information, drawings, dimensions, descriptions, or any direct or indirect damages, losses or costs resulting therefrom. Any cooling performance and general technical values indicated in this catalogue are measured at test conditions according to standard test procedures or calculated, based on such tests. They represent a basis for your product selection. Due to different conditions, test conditions and application environments the performance may also vary by up to 15%. All sound values are determined in accordance with ISO 9614-2, DIN EN ISO 11203 accuracy class C or Machinery Directive 2006/42/EG and are A-weighted. As some of the performance data, possible differences to comparison data are possible. The reason for that are no existing standard test procedures or individual suggestions, e.g. for cooling performance measurements. Therefore, we recommend all products to be checked under the system operating conditions. This also applies to vibrations and mechanical stress as well as for noise peaks and thermal stress or any other relevant factors. General tolerances according to DIN EN 2768-M. General tolerances for casted parts according to DIN ISO 3092-3 (DIN 3120). Tolerances for rubber parts are according to ISO 3302-1 (class V4-F100). The tolerances of welding seams are defined by quality group C according to DIN ISO 5817. If it is not specified on the actual CAD drawing or data sheet. Any form of liability is excluded for the information included in this data sheet. All details and calculation values are checked to the best of our ability, but these do not ensure any fit in products or parts due to the wide range of possible applications. It is advised that all technical data hereon should be confirmed through testing carried out by the end-user, our technology production and vertical GmH. These reserves apply to modifications to the product without any separate notification. This refers to all technical data of the product itself. Furthermore, it should be specified that the catalogues does not substitute the corresponding CAD drawings, as well as the installation, full details or the operating instructions. 00-Modular-Cooler-Unit-MCU-en-vid 04.ese.10.2019, November 2023 case 302

Fluid Controls

Air Cooled Range

Oil/Air Cooler / Pump Unit



High reliability, short lead times and best availability for wear parts are the arguments in favor of a combination of standard oil coolers with standard motor pump units. Contact us to select the optimal configuration for your application.

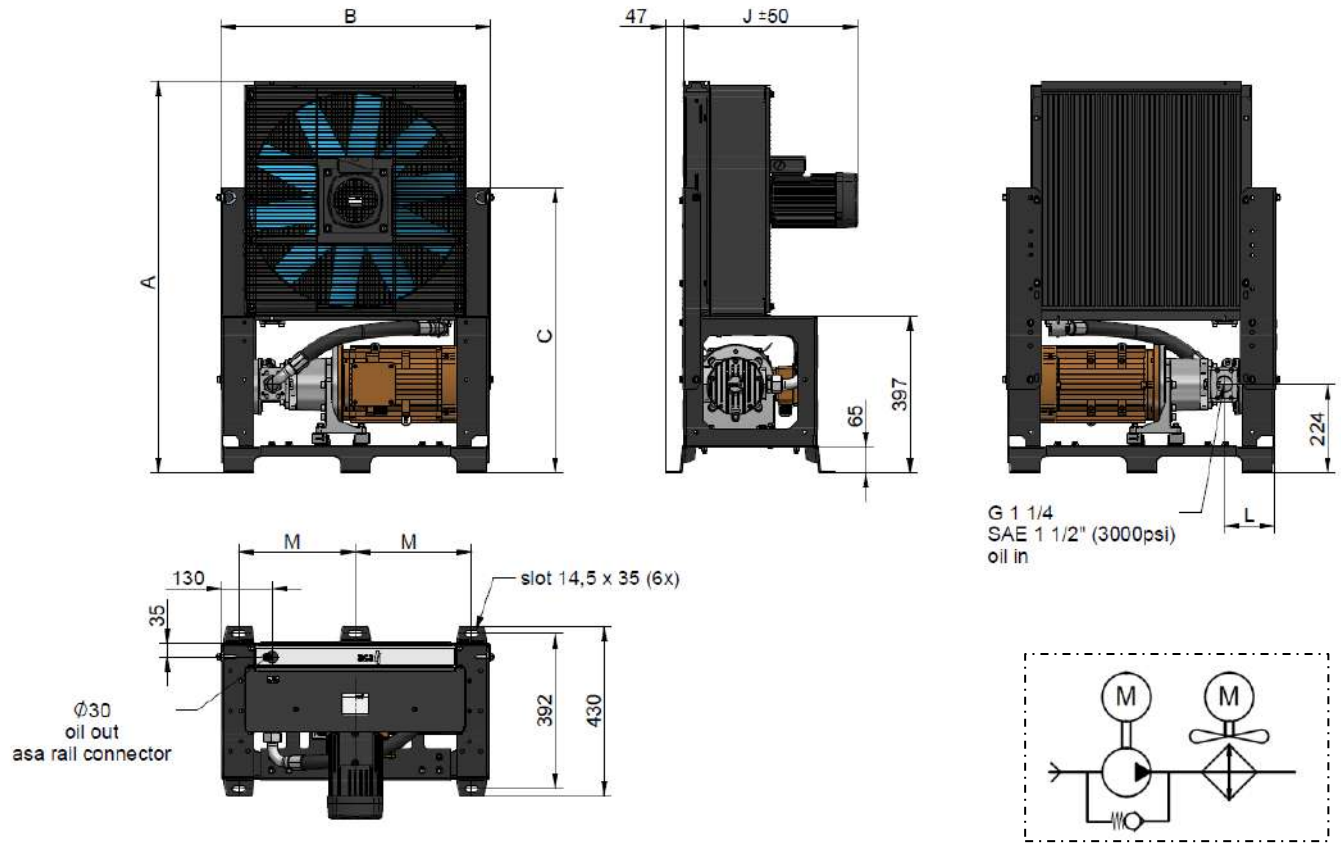

Dimensions

order number	description	A	B	C	J	I	M	weight
		[mm]	[mm]	[mm]	[mm]	[mm]	[mm]	[kg]
11111MP25.....	MCU 1125 ra1 G2 80cm ³ AC	997	687	170	447	131	295	88
11111MP36.....	MCU 1136 ra1 G2 80cm ³ AC	996	858	170	466	220	383	97

Technical Data

order number	description	cooler				motor / pump unit					spec. cooling power
		motor power	motor current	rotation	air flow	motor power	motor current	rotation	oil flow	displacement	P (spec.)
		[kW]	[A]	[rpm]	[kg/s]	[kW]	[A]	[rpm]	[l/min]	[cm ³ /rotation]	[kW/°C]
11111MP25.....	MCU 1125 ra1 G2 80cm ³ AC	0,75	1,7	1475	9,00	2,2	4,52	1435	102	80	0,67
11111MP36.....	MCU 1136 ra1 G2 80cm ³ AC			1450							0,77

This data sheet and the corresponding CAD drawings are to be used as a general guideline and technical overview of our products. Please contact us if more exact information is needed. As we are constantly improving our products, the characteristics, dimensions and weights may also change, although we do our best to incorporate these changes consistently. asa assumes no liability for any information, drawings, dimensions, misprints, errors or omissions, losses or costs resulting therefrom. Any cooling performance and general technical values indicated in this catalogue are measured at test conditions according to standard test procedures or calculated, based on such tests. They represent a basis for your product selection. Due to different conditions, test and application environments the performance may also vary by up to 15%. All sound values are determined in accordance with ISO 9614-2, DIN EN ISO 11203 accuracy class C or Machinery Directive 2006/42/EG and are Average. As some of the performance data, especially differences to standard data are possible. The reason for that are in particular detailed testing procedures or individual suggestions, also for cooling performance measurements. Therefore, we recommend all products to be checked under the system operating conditions. This is also true for vibrations and mechanical stress as well as for pressure peaks and thermal stress or any other relevant factors. General tolerances according to DIN ISO 2768-Ms. General tolerances for casted parts according to DIN ISO 8062-3 (DIN ISO 10). Tolerances for rubber parts are according to ISO 3302-1 (class V4-F100). The tolerances of welding seams are defined by quality group C according to DIN ISO 5817. If it is not specified on the actual CAD drawing or data sheet. Any form of liability is excluded for the information included in this data sheet. All details and calculation values are checked to the best of our ability, but these do not ensure any fit in product or operation due to the wide range of possible applications. It is advised that all technical data hereon should be confirmed through testing carried out by the end user. asa technology Products - and Vertrieb GmbH reserves the right to modify the product without any separate notification. This refers to both technical data and the product itself. Furthermore, it should be specified that the attached CAD files are not published during the corresponding CAD drawings, as they may not be installed. Full details on the operating instructions, 3D-Modular-Cooler-Unit-MCU-en-1x3
© asa technology, February 2024

Fluid Controls

Air Cooled Range

Oil/Air Cooler / Pump Unit



Cooling oil with ambient air is a very cost efficient way to maintain hydraulic fluids within its best working range. Our products, systems and solutions help to ensure best life-time performance, supply add-on values to the end user and reduce the energy consumption. We offer short lead times and the densest program of pressure-res' start coolers with all relevant features

Order Code

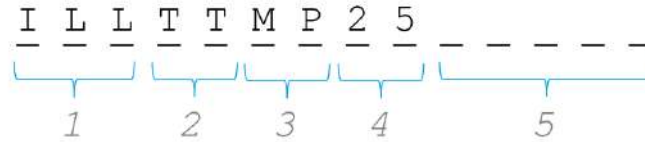

1 Product Category

ILL oil/air cooling

2 Product Series

TT TT rail series

3 Product Series

MP motor pump

4 Cooler Size

25 IIII

36 IIII

5 Customized

----- drawing no.

General Data

asa rail connector	ILL/AILI53G75 (HSP 1") or ILL/AILI53G3? (HSP 1 1/2")
AC – motor voltage	230/400V, 50 Hz
frame	powder coated steel
working temperature range	-20°C to +30°C (oil temperature)
working pressure:	10 bar
compatible media	any mineral oil acc. to DIN 51524



This data sheet and the corresponding CAD drawings are to be used as a general guideline and technical overview of our products. Please contact us if more exact information is needed. As we are constantly improving our products, their characteristics, dimensions and weights may also change, although we do our best to incorporate these changes continuously. asa assumes no liability for any information, drawings, misprints, errors or direct or indirect damages, losses or costs resulting therefrom. Any cooling performance and general technical values indicated in this catalogue are measured at test conditions according to standard test procedures or calculated, based on such tests. They represent a basis for your product selection. Due to different conditions, test conditions and application environments the performance may also vary by up to 15%. All sound values are determined in accordance with ISO 9614-2, DIN EN ISO 11203 accuracy class C or Vibration Directive 2006/42/EG and are Average. As some of the performance data, especially differences to the test conditions are possible. The reason for that are in order to factor detailed test procedures or individual suggestions, also for cooling performance measurements. Therefore, we recommend all products to be checked under the system operating conditions. This is also true of vibrations and mechanical stress as well as for pressure peaks and thermal stress and any other relevant factors. General tolerances according to DIN EN ISO 2768-Ms. General tolerances for casted parts according to DIN ISO 60623 (DIN 1010). Tolerances for rubber parts are according to ISO 3302-1 (class V4-F100). The tolerances of welding seams are defined by quality group D according to DIN ISO 5817. If it is not specified on the actual CAD drawing or data sheet. Any form of liability is excluded for the information included in this data sheet. All details and calculation values are checked to the best of our ability, but these do not ensure any fit in product operation due to the wide range of possible applications. It is advised that all technical data hereon included be confirmed through testing carried out by the end user, our technology products and service team. These test results may be modified by the product without any separate notification. This refers to all technical data on the product itself. Furthermore, it should be noted that the contact heat does not apply during the corresponding CAD drawings, as well as the installation, delivery and the operating instructions. 00-Modulair-Cooler-Unit-MCU-01-en-6x0
© ase technology, February 2024

Fluid Controls

Water Cooled Range

Plate Heat Exchanger / Pump Unit



Compact water-cooled plate heat exchangers in combination with a pump unit can save space and weight. Please contact us to discuss the possible options and perfect fit for the actual application.

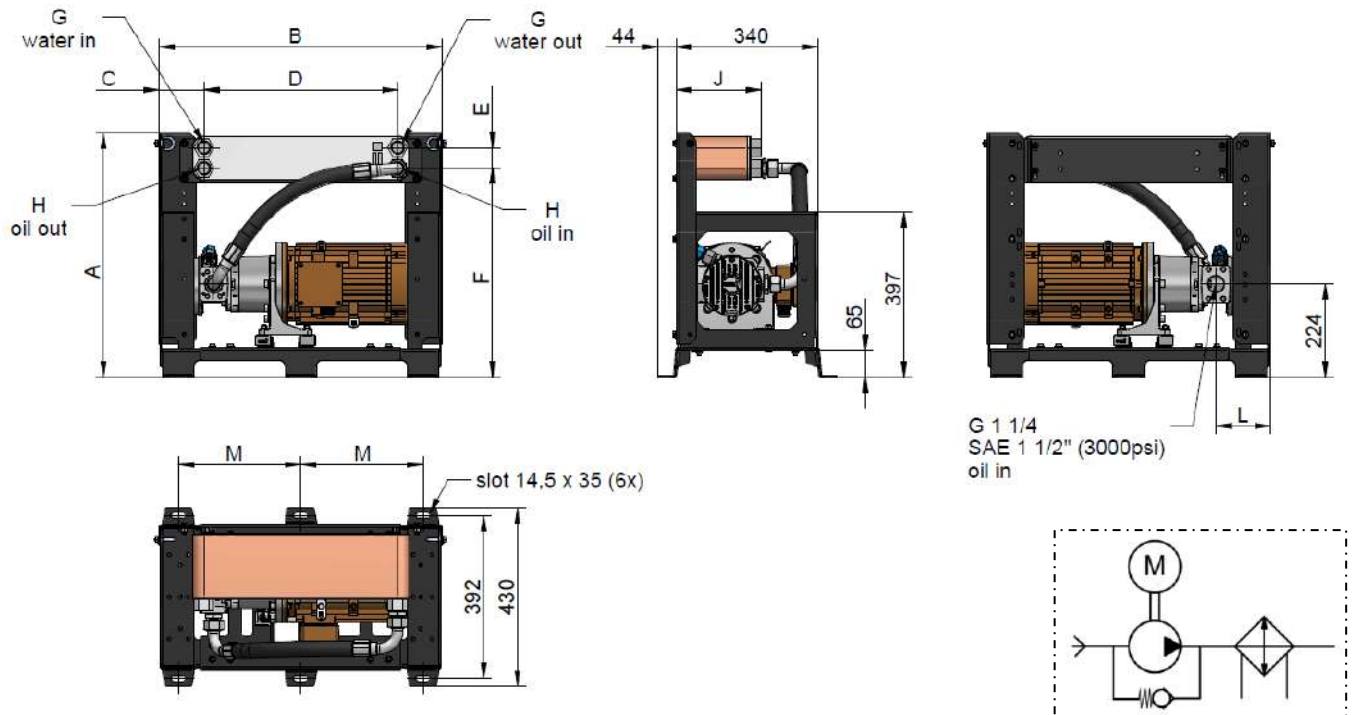

G 1 1/4
SAE 1 1/2" (3000psi)
oil in

Dimensions

order number	description	A	B	C	D	F	F	G	H	J	I	M	weight
		[mm]	[mm]	[mm]	[mm]	[mm]	[mm]	[BSPP]	[BSPP]	[mm]	[mm]	[mm]	[kg]
II WPI MP5/5....	MCU PI 4b G2 80cm ² AC	587	682	108	466	50	496	G 1"	G 1"	206	131	297	60
II WPI MP5/3....	MCU PI 53 G2 80cm ² AC	587	682	119	447	64	489	G 1"	G 1"	156	131	297	63
II WPI MP6/6....	MCU PI 6b G2 80cm ² AC	595	771	126	519	92	456	G 1 1/2"	G 1 1/2"	135	176	339	76
II WPI MP7/0....	MCU PI 70 G2 80cm ² AC	70	682	113	456	177	493	G 1 1/2"	G 1 1/2"	110	131	297	83

Technical Data

order number	description	motor / pump unit					spec. cooling power
		motor power	motor current	rotation	oil flow	displacement	P (spec.)
		[kW]	[A]	[rpm]	[l/min]	[cm ³ /rotation]	[kW/°C]
II WPI MP5/5....	MCU PI 4b G2 80cm ² AC	2,2	4,52	1435	102	80	1,13
II WPI MP5/3....	MCU PI 53 G2 80cm ² AC						1,14
II WPI MP6/6....	MCU PI 6b G2 80cm ² AC						1,12
II WPI MP7/0....	MCU PI 70 G2 80cm ² AC						1,21

This data sheet and the corresponding CAD drawings are to be used as a general guideline and technical overview of our products. Please contact us if more exact information is needed. As we are constantly improving our products, the characteristics, dimensions and weights may also change, although we do our best to incorporate these changes continuously. asa assumes no liability for any information, drawings, dimensions, misprints, errors or omissions, omissions, losses or costs resulting therefrom. Any cooling performance and general technical values indicated in this catalogue are measured at test conditions according to standard test procedures or calculated, based on such tests. They represent a basis for your product selection. Due to different conditions, test conditions and application environments the performance may also vary by up to 15%. All such values are determined in accordance with ISO 9614-2, DIN EN ISO 11203 accuracy class C or Machinery Directive 2006/42/EG and are Average. At some of the performance data, possible differences to the test conditions are possible. The reason for that are in particular detailed test procedures or individual suggestions, also for cooling performance measurements. Therefore, we recommend all products to be checked under the system operating conditions. This is also true of vibrations and mechanical stresses as well as for pressure peaks and thermal stress and any other relevant factors. General tolerances according to DIN EN ISO 2768-Ms. General tolerances for casted parts according to DIN ISO 8062-3 (DIN 1010). Tolerances for rubber parts are according to ISO 3302-1 (class V4-F100). The tolerances of welding seams are defined by quality group D according to DIN ISO 5817. If it is not specified on the actual CAD drawing or data sheet. Any form of liability is excluded for the information included in this data sheet. All details and calculation values are checked to the best of our ability, but these do not ensure any fit in your product or application due to the wide range of possible applications. It is advised that all technical data are to be checked by the end user, our technology products and vertical GMAI reserves the right to modify the product without any separate notification. This refers to both technical data and the product itself. Turnover: 1.10.2024. If specified that the plate heat exchanger is not suitable for the corresponding CAD drawings, please refer to the installation and operation instructions. 09-Modular-Cooler-Unit-MCU-en-6x0
© ase technology, February 2024

Fluid Controls

Water Cooled Range

Plate Heat Exchanger / Pump Unit



The asa H plate heat exchanger is designed for maximum heat transfer using profiled plates of acid proof stainless steel. The plates form channels through which oil and water pass (alternating every other channel). At the front and back side of the plate package there are cover plates. The cooler plates are brazed together at all outer and inner points of contact. The cooler can be installed in charge-pump circuits as well as in return lines with high pressure variations. This product is also suitable for water, air and gas.

Order Code

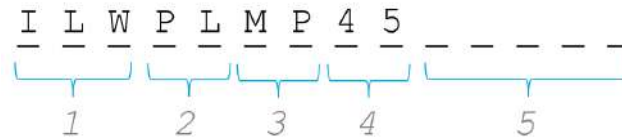

1 Product Category

I L W oil/water cooling

2 Product Series

PI plate heat exchanger series

3 Product Series

MP motor pump

4 Cooler Size

4b
53
6b
70

I L W P I

5 Customized

----- drawing no.

General Data

AC – motor voltage	230/400V, 50 Hz
frame	powder coated steel
working temperature range	-20°C to +80°C (oil temperature)
working pressure:	max. 10 bar
pump: compatible media (oil side)	any mineral oil acc to DIN 51524
plate heat exchanger: compatible media (water side)	water, water-glycol



This data sheet and the corresponding CAD drawings are to be used as a general guideline and technical overview of our products. Please contact us if more exact information is needed. As we are constantly improving our products, their characteristics, dimensions and weights may also change, although we do our best to incorporate these changes continually. asa assumes no liability for any information, drawings, impressions, misprints, errors or direct or indirect damages, losses or costs resulting therefrom. Any cooling performance and general technical values indicated in this catalogue are measured at a test set-up according to standard procedures or calculated, based on such tests. They represent a basis for your product selection. Due to different conditions, settings and application environments the performance may also vary by up to 15%. All sound values are determined in accordance with ISO 9614-2, DIN EN ISO 11203 accuracy class C or Maschinen Directive 2006/42/EG and are A-weighted. As some of the performance data, especially differences to standard data are possible. The reason for that are in particular detailed testing procedures or individual suggestions, also for cooling performance measurements. Therefore, we recommend all products to be checked once in the system operating conditions. This is also true for vibrations and mechanical stress as well as for pressure peaks and thermal stress or any other relevant factors. General tolerances according to DIN EN ISO 2768-M, general tolerances for casted parts according to DIN ISO 60623 (DIN 1073-10). Tolerances for rubber parts are according to ISO 3302-1 (class V4-F100). The tolerances of welding seams are defined by quality group C according to DIN ISO 5817. If it is not specified on the actual CAD drawing or data sheet. Any form of liability is excluded for the information included in this data sheet. All details and calculation values are checked to the best of our ability, but these do not ensure any return product or repair due to the working in the possible applications. It is advised that all technical data of the product itself, furthermore, to be verified if specified that the contact heat exchanger does not put during the corresponding CAD drawings, as well as the installation, full details on the operator instructions, 00-Modul-Öl-Wasser-Ühr-MCU-Öl-Wasser
© ase technology, February 2024 7/22

Fluid Controls

Water Cooled Range

Shell & Tube Heat Exchanger / Pump Unit



Water-cooled shell & tube heat exchangers can be combined with our oil pump units with integrated filter function. Contact us to select the best options from our portfolio.

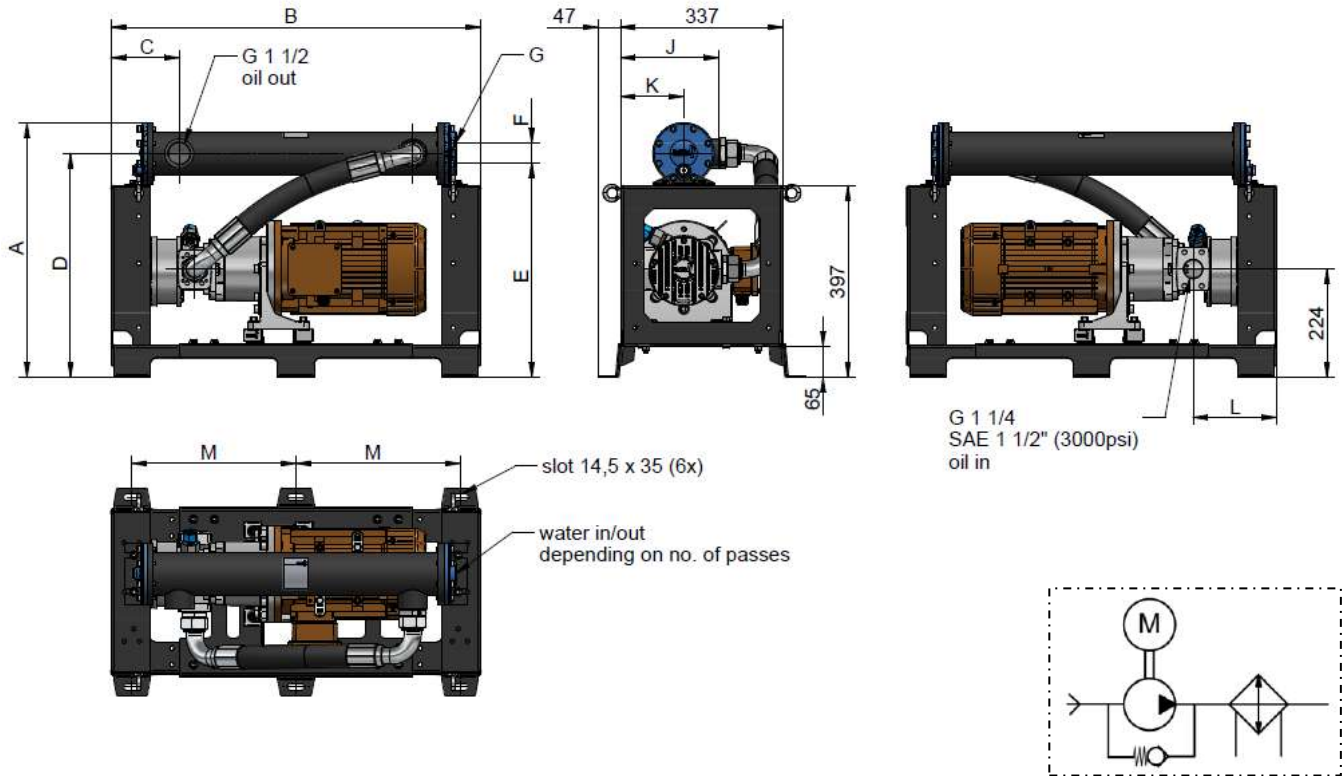

Dimensions

order number	description	A	H	C	D	F	F	G	J	K	I	M	weight
		[mm]	[mm]	[mm]	[mm]	[mm]	[mm]	[BSP/1"]	[mm]	[mm]	[mm]	[mm]	[kg]
II WSI MP03.....	MCU SI03 G2 80cm ² AC	527	765	141	463	447	41	3/4"	207	130	1/3	339	65
II WSI MP05.....	MCU SI05 G2 80cm ² AC	581	765	157	499	463	61	1"	205	118	1/3	339	70

Technical Data

order number	description	motor / pump unit					spec. cooling power
		motor power	motor current	rotation	oil flow	displacement	P (spec.)
		[kW]	[A]	[rpm]	[l/min]	[cm ³ /rotation]	[kW/°C]
II WSI MP03.....	MCU SI03 G2 80cm ² AC	2,2	4,52	1435	107	80	1,02...1,45*
II WSI MP05.....	MCU SI05 G2 80cm ² AC						

* Value for 2-pass and 4-pass versions, tube diameter brmm.
See section see data sheet: Shell & Tube Heat Exchanger.

Fluid Controls

Water Cooled Range

Shell & Tube Heat Exchanger/ Pump Unit



Our SI series is a modular range of shell and tube design heat exchangers. The main benefits of this design are the versatility of applications more independent of the used fluid quality and good maintenance ability compared to other heat exchanger types. Our modular setup allows the best suitable connection and low principle for lowest pressure drop at highest cooling performance. We supply single or more pass configurations as well as different material combinations. For raising efficiency we offer all these configurations with hybrid finned tube technology.

Order Code

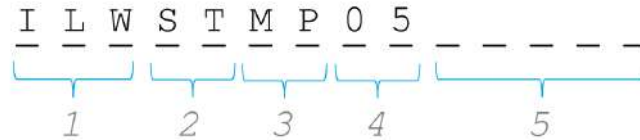

1 Product Category

III W oil/water cooling

2 Product Series

SI shell & tube series

3 Product Series

MP motor pump

4 Cooler Size / Product Series

03 III W S I

0b

5 Customized

----- drawing no.

General Data

AC – motor voltage	230/400V, 50 Hz
frame	powder coated steel
working pressure	max. 10 bar
working temperature range	-20°C to +80°C (oil temperature)
pump: compatible media (oil side)	any mineral oil acc to DIN 51524
shell & tube heat exchanger: compatible media (water side)	water, water glycol, sea water

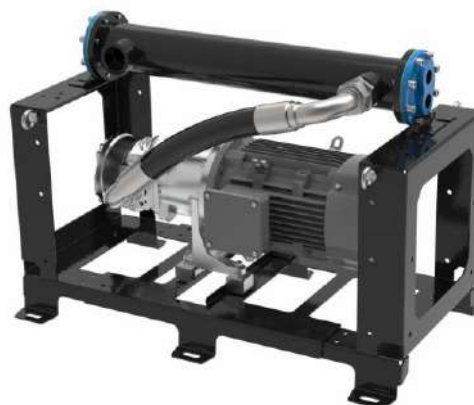

This data sheet and the corresponding CAD drawings are to be used as a general guideline and technical overview of our products. Please contact us if more exact information is needed. As we are constantly improving our products, their characteristics, dimensions and weights may also change, although we do our best to incorporate these changes continuously. asa assumes no liability for any information, omissions, misprints, or any direct or indirect damages, losses or costs resulting therefrom. Any cooling performance and general technical values indicated in this catalogue are measured at a test bench according to standard test procedures or calculated, based on such tests. They represent a basis for your product selection. Due to different conditions in testing and application environments the performance may also vary by up to 15%. All sound values are determined in accordance with ISO 9614-2, DIN EN ISO 11203 accuracy class C or Machinery Directive 2006/42/EC and are A-weighted. As some of the performance data, especially differences to standard data are possible. The reason for that are in order to tailor detailed testing procedures or individual suggestions, e.g. for cooling performance measurements. Therefore, we recommend all products to be checked under the system operating conditions. This is also true for vibrations and mechanical stress as well as for pressure peaks and thermal stress and any other relevant factors. General tolerances according to DIN EN ISO 2768-Ms. General tolerances for casted parts according to DIN ISO 80623 (DIN 10203 L10). Tolerances for rubber parts are according to ISO 3302-1 (class V4-F100). The tolerances of welding seams are defined by quality group D according to DIN ISO 5817. If it is not specified on the actual CAD drawing or data sheet. Any form of liability is excluded for the information included in this data sheet. All details and calculation values are checked to the best of our ability, but these do not ensure any fit in products or compatibility to the wide range of possible applications. It is advised that all technical data hereon be confirmed through testing carried out by the end user, our technology production and service team. These test results may not be used for the product without any separate notification. This refers to all technical data of the product itself. Turnover: 1.087.000, if specified that the contact address is not public during the corresponding order drawing, as per usual installation. Full details on the operating instructions. 00-Modular-Cooler-Unit-MCU-01-en-1x0
© ase technology, February 2024

COMPANY

asa stands for developments, advances and innovations already at work through our customers' various mobile and stationary applications. More than 40 years experience in thermal systems, connection technology and Fluid control has made us a global leader in advanced technologies. Our experience creates progress to ensure you competitive pricing, consistent product performance and reliability.



Be different. Make a difference.

Over the years, asa continually developed into a globally active systems supplier. Despite this evolution, we consciously maintained the medium sized structure of a family owned company. As a result, we are able to respond quickly and flexibly to our customer's demands and promote our innovations. Our increasing product portfolio and quality targets developed asa as a brand to the next level. Thus made us create a new logo and appearance to strengthen our key values and highlight it in all our present and future markets. We are proud on looking back on more than 40 years of innovative products, but our major attitude is the view into the future. Please check out our newest products and technologies in this catalogue and contact us if more detailed information is required.

Quality References

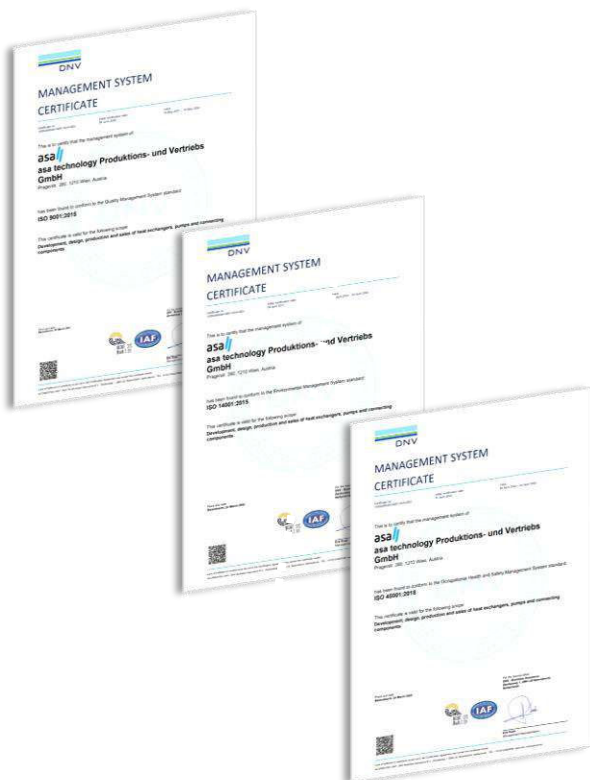

History

- **1980**
Foundation in Vienna, Austria
Production of expansion joint and butterfly valves
- **1984**
Manufacturing Shell & Tube type heat exchanger „Silver 180“
- **1988**
Worldwide first modular cooler system in plate & bar „DKO“
- **1993**
Foundation of asa hydraulik of America Inc., Branchburg / New Jersey
- **2000**
“1 Flexible connectors”
More than 100.000 produced cooling systems of the patented asa universal connectors
- **2007**
Foundation of asa hydraulik of Kunshan / China, manufacturing modular cooler range “11-Ra1” / 3 brazing lines
- **2014**
Foundation of asa Products Pty Ltd in Hopping/Australia
- **2016**
New manufacturing sites in asa Hydraulik Technology Suzhou/China, 5 brazing lines
- **2019**
New R&D center in Vienna / Austria
Foundation of asa heatexchanger Pvt Ltd in Ahmedabad / India
start of new brazing line
- **2022**
Foundation of asa hydraulik do Brasil Pvt Ltd a. in Sao Paulo / Brazil
Manufacturing site of patented asa “FW” heat transfer system

discover reliable
technology!

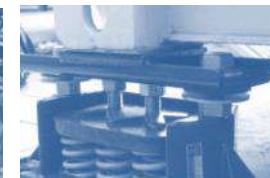
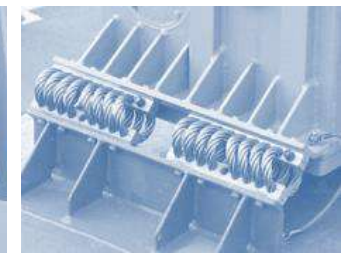
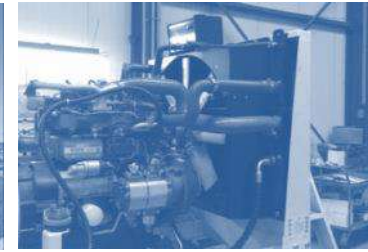
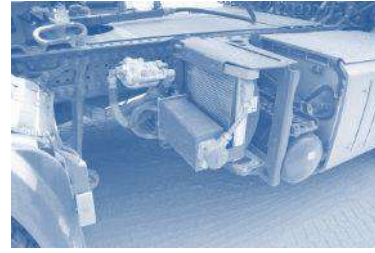
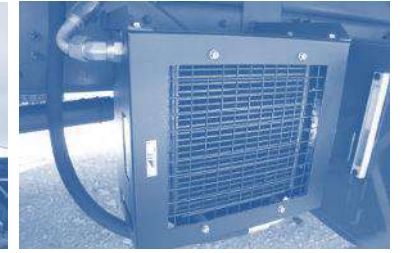
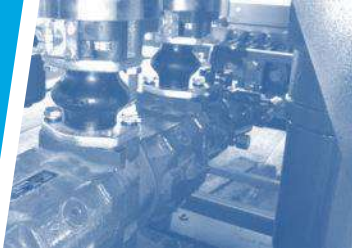

**be different.
make a difference.**

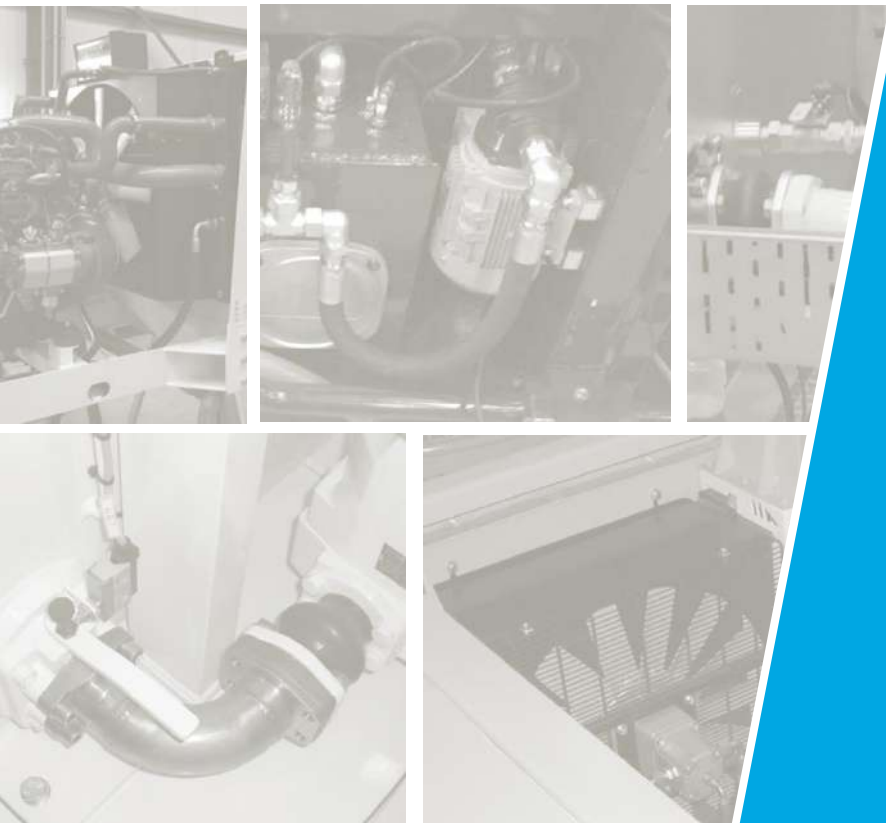

AUSTRIA

asa technology Produktions-
und Vertriebs GmbH
Prager Strasse 280
A-1210, Vienna
Tel.: +43 1 282 40 20
support@asahydraulik.com

AUSTRALIA

asa Products Pty Ltd
Quinlan Road 23
3076 Epping, Victoria
Tel.: +61 3 9397 6129
melbourne@asanydraulik.com

BRASIL

asa hydraulik do Brasil Ltda
Rua Maria Fett 96
03263-000 V L Mercedes, Sao Paulo
Tel.: +55 11 9 8862-0022
sa.es_brazil@asanydraulik.com

CHINA

asa Hydraulik Technology (Suzhou) Co.Ltd
江苏省苏州市工业园区方洲路128号6区B幢
Area 6, Building B,
Fangzhou Road No 128,
Suzhou Industrial park,
Suzhou City, Jiangsu Province
Tel.: +86 512 62381988
suzhou@asanydraulik.com

INDIA

asa heatexchanger Pvt Ltd
Plot no.1226, Phase-3, GIDC, Vatva
Ahmedabad - 382445
Tel.: +91 70 43907273
sa.esindia@asanydraulik.com

USA

asa hydraulik of America
160 Meister Avenue 20 A
Branchburg, New Jersey 08876
Tel.: +1 800 473 94 00
Tel.: +1 908 541 15 00
sa.es_us@asanydraulik.com